

Ana Ürünler Katalođu

Main Product Catalogue

Haziran / June **2022**

 **CE** **WRAS** **ERC**
Water Regulations Advisory Scheme





     /DuyarVana | Duyar.com

DUYAR 
Since 1965

DUYAR



   
Water Regulations Advisory Scheme

     /DuyarVana | Duyar.com



İçindekiler

Index

Statik Balans Vanası Flanşlı (PN 16) Static Balancing Valve Flanged (PN 16)	06	Buşakle Takımı Surface Box	20
Statik Balans Vanası Bronz Dişli (PN 25) Static Balancing Valve Bronze Threaded (PN 25)	07	Wafer Kelebek Vana (PN 25) Wafer Butterfly Valve (PN 25)	21
Lug Küresel Vana (PN 16) Lug Ball Valve (PN 16)	08	Kauçuk Kaplı Wafer Kelebek Vana (PN 16) Rubber Coated Wafer Butterfly Valve (PN 16)	22
Tam Geçişli Küresel Vana (2 Parçalı PN 6) Full Bore Ball Valve (2 Pcs PN 6)	09	Wafer Vulkanize Kelebek Vana (Nikel Klapeli, PN16) Wafer Vulcanized Butterfly Valve (Nickel Clapper, PN16)	23
Tam Geçişli Küresel Vana (2 Parçalı PN 16) Full Bore Ball Valve (2 Pcs PN 16)	10	Wafer Vulkanize Kelebek Vana (Paslanmaz Klapeli, PN 16) Wafer Vulcanized Butterfly Valve (Stainless Steel Clapper, PN 16)	24
Tam Geçişli Küresel Vana (2 Parçalı PN 16) Full Bore Ball Valve (2 Pcs PN16)	11	Lug Vulkanize Kelebek Vana (Nikel Klapeli, PN16) Lug Vulcanized Butterfly Valve (Nickel Clapper, PN16)	25
Tam Geçişli Küresel Vana (3 Parçalı PN 16) Full Bore Ball Valve (3 Pcs PN 16)	12	Lug Vulkanize Kelebek Vana (Paslanmaz Klapeli, PN16) Lug Vulcanized Butterfly Valve (Stainless Steel Clapper, PN 16)	26
Tam Geçişli Küresel Vana (Dişli PN 16) Full Bore Ball Valve (Threaded PN 16)	13	Yivli Kollu Kelebek Vana Groove to Groove Butterfly Valve	27
Gaz Küresel Vana (3 Parçalı Mop 5Hvac20/PN 16/PN 25) Gas Ball Valve (3 Pcs Mop 5Hvac20/PN 16/PN 25)	14	Kelebek Vana Dişli Kutulari (Redüktör) Butterfly Valve Gear Box	28
Metal Yataklı Sürgülü Vana (F4) Metal Seated Gate Valve (F4)	15	Glob Vana (PN 16) Globe Valve (PN 16)	30
Elastomer Sitli Sürgülü Vana (PN 16, F4) Resilient Seated Gate Valve (PN 16, F4)	16	Metal Körüklü Glob Vana (PN 40) Metal Bellows Sealed Globe Valve (PN 40)	31
Elastomer Sitli Sürgülü Vana (PN 16, F4) Resilient Seated Gate Valve (PN 16, F4)	17	Metal Körüklü Glob Vana (PN 16) Metal Bellows Sealed Globe Valve (PN 16)	32
Elastomer Sitli Sürgülü Vana (PN 16, F5) Resilient Seated Gate Valve (PN 16, F5)	18	Tam Kalkışlı Emniyet Ventili (Yaylı, PN 16) Full Lift Safety Valve (With Spring, PN 16)	33
Yükselen Milli Metal Yataklı Sürgülü Vana (F4) OS&Y Metal Seated Gate Valve (F4)	19		

Oransal Kalkışlı Emniyet Ventili (Yaylı, PN 16) Proportional Lift Safety Valve (With Spring, PN 16)	34
Ters Kovalı Kondenstop (Flanşlı - Dişli, PN 16) Inverted Bucket Steam Trap(Flanged - Threaded, PN 16)	35
Disk Tip Çek Vana Pirinç (PN 16) Disc Type Check Valve Brass (PN 16)	36
Disk Tip Çek Vana Sfero Döküm (PN 16) Disc Type Check Valve (Angle Type, PN 16)	37
Çift Klapeli Çek Valf (PN 16) Dual Plate Check Valve (PN 16)	38
Yaylı Çek Vana (PN 16) Check Valve (With Spring PN 16)	39
Çalpara Çek Vana (PN 16) Swing Check Valve (PN 16)	40
Wafer Çalpara Çek Valf (PN 16) Wafer Swing Check Valve (PN 16)	41
Lug Pislik Tutucu (PN 16) Lug Strainer (PN 16)	42
Y Tipi Pislik Tutucu (PN 16) Y Type Strainer (PN 16)	43
Y Tipi Pislik Tutucu Manometreli, PN16 Y Type Strainer With Pressure Gauge	44
Yer Üstü Yangın Hidranti (PN 16) Overground Fire Hydrant (PN 16)	46
Yer Üstü Yangın Hidranti (PN 16) Overground Fire Hydrant (PN 16)	47
Yer Altı Yangın Hidranti (PN 16) Underground Fire Hydrant (PN 16)	48
Kauçuk Kompansatör (Flanşlı, PN 16) Rubber Expansion Joint (Flanged, PN 16)	49
Kauçuk Kompansatör (Dişli, PN 16) Rubber Expansion Joint (Threaded, PN 16)	50
Metal Körüklü Kompansatör (Döner Flanşlı, Laynersiz, PN 16) Metal Bellows Expansion Joints (Rotary Flanged, Without Liner, PN 16)	51
Metal Körüklü Kompansatör (Döner Flanşlı, Laynerli, PN 16) Metal Bellows Expansion Joints (Rotary Flanged, With Liner, PN 16)	52

Metal Körüklü Kompansatör (Kaynak Boyunlu, Laynersiz, PN 16) Metal Bellows Expansion Joints (Welding Neck, Without Liner, PN 16)	53
Metal Körüklü Kompansatör (Dıştan Basınçlı, Flanşlı, PN 16) Metal Bellows Expansion Joints (External Pressured, Flanged, PN 16)	54
Metal Körüklü Kompansatör, Dıştan Basınçlı (Kaynak Boyunlu, PN 16) Metal Bellows Expansion Joints, Externally Pressured (With Welding Neck, PN 16)	55
Limit Rotlu Metal Kompansatör PN16 (Flanged) Metal Bellows Expansion Joints, With Limiting Rod PN16 (Flanged)	56
Kardan Mafsallı Deprem Kompansatörleri (Flanşlı PN16) Gimbal Type Expansion Joints (Flanged)	57
Kardan Mafsallı Deprem Kompansatörleri (Kaynak Boyunlu PN16) Gimbal Type Expansion Joints Expansion Joints (With Welded Neck)	58
Dilatasyon Kompansatörleri, Limit Rotlu (Flanşlı, PN 16) Dilatation Expansion Joints, With Limiting Rod (Flanged, PN 16)	59
Dilatasyon Kompansatörleri, Limit Rotlu (Kaynak Boyunlu, PN 16) Dilatation Expansion Joints, With Limiting Rod (With Welding Neck, PN 16)	60
Pirinç Küresel Vana (Dişli, PN 25) Brass Ball Valve (Threaded, PN 25)	61
Pirinç Küresel Vana, Kelebek Kollu (Dişli, PN 25) Brass Ball Valve, With Butterfly Lever (Threaded, PN 25)	62
Pirinç Küresel Vana, İzolasyon Boyunlu (Dişli, PN 25) Brass Ball Valve, With Stem Extension (Threaded, PN 25)	63
Pirinç Mini Küresel Vana (PN 16) Brass Mini Ball Valve (PN 16)	64
Pirinç Yaylı Çek Vana (Dişli, PN 16) Brass Check Valve With Spring (Threaded, PN 16)	65
Y Tipi Pislik Tutucu (Pirinç, Dişli, PN 16) Y Type Strainer (Brass, Threaded, PN 16)	66
Otomatik Purjör (PN 10) Automatic Air Vent (PN 10)	67

1965

- Kuruluş
Establishment
- Sürgülü Vana İmalatı
Production of Gate Valves



1967

- Küresel Vana İmalatı
Production of Ball Valves

2010

- İlk UL/FM Onayının Alınması
(OS&Y Sürgülü Vana)
Getting of the First UL/FM Approvals
(OS&Y Gate Valve)
- Türkiye'de İlk Test Drenaj Vanası İmalatı
First Production of Test and Drain Valve
in Turkey

2009

- Yerli Yangın Ürünleri İmalatı
Production of Domestic Fire Fighting Products
- Türkiye'de İlk Balans Vanası İmalatı
First Production of Balancing Valve in Turkey



2016

- Sprinklere UL/FM Alınması
Getting UL/FM Approvals for Sprinkler Heads
- IFSA (International Fire Sprinkler Association Üyeliği
Membership of IFSA (International Fire Sprinkler Association)
- Yeni Nesil Vulkanize Kelebek Vana İmalatı
Production of New Generation Vulcanized Butterfly Valve



2018

- Türkiye'de İlk Akış Anahtarı İmalatı
First Production of Flow Switch Produce in Turkey
- Islak Alarm UL Alınması
Getting UL Approvals for Wet Alarm Valve
- Türkiye'de İlk Kolay Kurulum Ünitesi İmalatı
First Production of Commerical Riser Manifold Produce in Turkey



2019



- İzlenebilir Kelebek Vana FM/UL Belgesi Alınması
Getting UL/FM Approved for Indicator Butterfly Valve
- Kolay Kurulum Ünitesi UL Belgesi Alınması
Getting UL Approval for Riser Manifold
- Türkiye'de ilk K: 22.4 ESFR Sprinkler İmalatı
First Production of K:22.4 ESFR Sprinkler in Turkey



2012



- Türkiye'de İlk Sprinkler Üretimi
*First Production of Sprinkler Head
Production in Turkey*
- Türkiye'de İlk Islak Alarm Vanası İmalatı
*First Production of Wet Alarm
Valve Production in Turkey*
- İlk Lug Küresel Vana üretimi
First Production of Lug Ball Valve in Turkey

2011

- Kompakt Küresel Vana ve Patentli Lug Pislük Tutucu İmalatı

*Production of Compact Ball Valve and
Lug Strainer With Patents*

- İnovatif Lug Pislük Tutucu İstanbul Sanayi Odası (İSO) tarafından düzenlenen 13. Çevre ve Şehircilik Ödül Töreni'nde "Enerji Verimli Ürün" kategorisinde 3.lük ödülü aldı.

*Innovative Lug Strainer won the 3rd prize in
the "Energy Efficient Product" category at
the 13th Environment and Urbanization Award
Ceremony organized by Istanbul Chamber of
Industry (ISO)*



2013



- Islak Alarm FM Alınması
Getting FM Approval for Wet Alarm Valve
- Yangın Ürünleri TSE Alınması
Getting TSE for Fire Products
- Türkiye'de İlk Yangın Laboratuvarının Kurulması
Establishing the First Fire Laboratory in Turkey



2014



- Tüm Yangın Ürünlerine Gost Belgesi Alınması
*Getting Gost Certificate for All Fire
Products*

2015

- Türkiye'de İlk Kuru Alarm Vanası İmalatı
*First Production of Dry Alarm Valve
Produce in Turkey*



2020

- Pre-Action & Deluge Vana İmalatı
Production of Pre-Action & Deluge Valve
- Türkiye'de ilk Yivli İzlenebilir Kelebek Vana İmalatı
*First Production of Groove Type Indicating
Butterfly Valve in Turkey*
- Türkiye'de ilk Basınç Anahtarı İmalatı
First Production of Pressure Switch in Turkey



2021



- Türkiye'de ilk Akış Anahtarı FM Belgesi Alınması
Getting FM Approved for Flow Switch
- Türkiye'de İlk Basınç Anahtarı FM Belgesi Alınması
Getting FM Approved for Pressure Switch
- Türkiye'de İlk Dişli Akış Anahtarı İmalatı
First Production of Flow Switch Threaded in Turkey
- Türkiye'de İlk Dişli Riser Manifold İmalatı
First Production of Residential Riser Manifold in Turkey
- Türkiye'de İlk OS&Y İzleme Anahtarı İmalatı
First Production of OS&Y Supervisory Switch
- Türkiye'de İlk Yivli İzlenebilir Kelebek Vana UL Belgesi Alınması
*First Getting UL Approved for Groove Type Indicating
Butterfly Valve in Turkey*



2022



- Yivli İzlenebilir Kelebek Vana FM Belgesi Alınması
*Getting FM Approved for
Indicating Butterfly Valve Grooved*
- Islak Alarm Vanası CE Belgesi Alınması
*Getting CE Certificate
for Wet Alarm Valve*



Pik Döküm / Cast Iron

T-3020

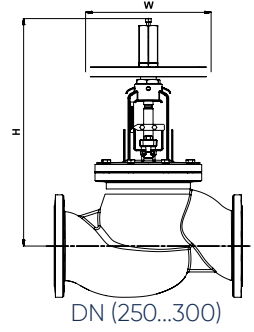

Genel Özellikler / General Specifications

Çalışma Sıcaklık Aralığı / Working Temperature : -10 ... +120 °C (16 Bar)

Standartlar / Standards

Sertifikalar / Certificates :

Tasarım / Design : TS EN 13789

Flanş Boyutları / Flange Dimensions : TS EN 1092-2 (PN 16)

Bağlantı Boyutları / Connection Dimensions : TS EN 1092-2 (PN 16)

Testler / Tests : TS EN 12266-1

Uygulamalar / Applications

Isıtma soğutma ve diğer su sistemleri

Heating and cooling systems and other water systems

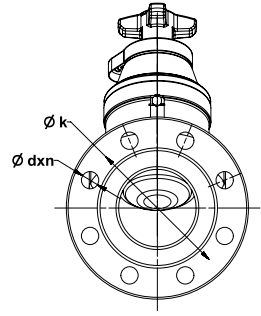
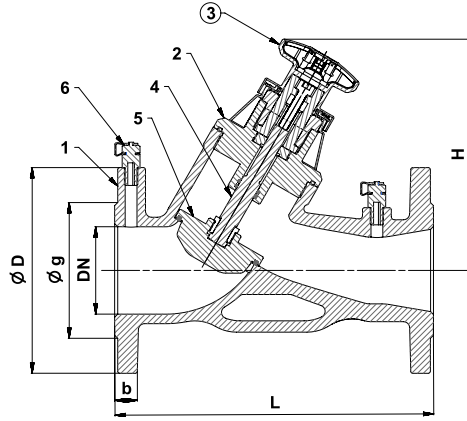

Malzeme Özellikleri Material Specifications

No	Parça Adı / Part Name	Malzeme / Material
1	Gövde/Body	GG 25 - EN GJL 250 - Pik Döküm / Cast Iron
2	Kapak/Bonnet	GG 25 - EN GJL 250 - Pik Döküm / Cast Iron
3	Valan/Handwheel	DN 40-150, Ebonit/Ebonite, DN 200-300, GG 25-EN GJL 250 - Pik Döküm / Cast Iron
4	Mil/Stem	X20Cr13 - AISI420 - Paslanmaz Çelik / Stainless Steel
5	Klape/Disc	GGG 40 - EN GJS 400-15 - Sfero Döküm + Kauçuk Kaplama / Ductile Iron + Rubber Coated
6	Ölçüm Probu/Measurement Probe	CuZn40Pb2 - CW617N - Pirinç / Brass



Ölçüler Dimensions

Anma Basıncı Nominal Pressure	16 Bar											
Anma Çapı Nominal Diameter	DN	40	50	65	80	100	125	150	200	250	300	
Vana Boyutları Valve Dimensions	L	200	230	290	310	350	400	480	600	730	850	
	H	176	190	214	225	334	388	403	825	900	945	
	W	86				160			400			
	D	150	165	185	200	220	250	285	340	405	460	
	g	84	99	118	132	156	184	211	266	319	370	
	k	110	125	145	160	180	210	240	295	355	410	
	b	18	20		22	24	26		30	32		
Ağırlık Weight	Kg	8,65	11,60	15,8	20,45	36,45	69,2	95,6	182	275,8	311,5	

Bronz Döküm / Cast Bronze

T-3010

Genel Özellikler / General Specifications
Çalışma Sıcaklık Aralığı / Working Temperature : -10 ... +120 °C (25 Bar)

Standartlar / Standards
Diş Standardı / Thread Standard : ISO 7-1
Testler / Tests : TS EN 12266-1

Uygulamalar / Applications
Isıtma soğutma ve diğer su sistemleri
Heating and cooling systems and other water systems

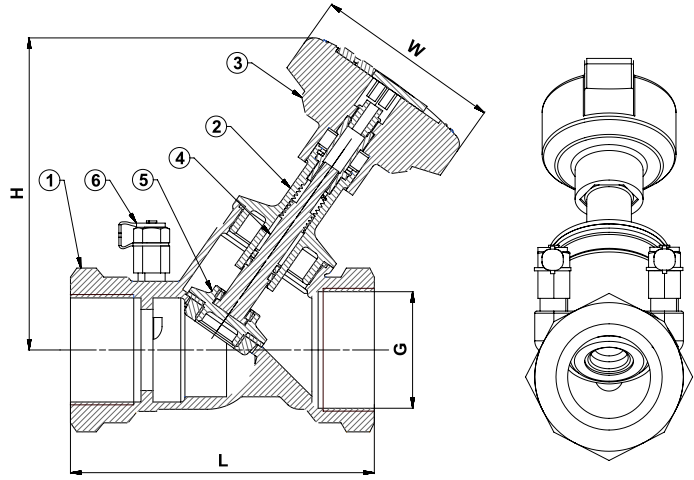

Malzeme Özellikleri Material Specifications

No	Parça Adı / Part Name	Malzeme / Material
1	Gövde / Body	G-CuSn5Zn5Pb5 - Rg5 - Bronz Döküm / Cast Bronze
2	Kapak / Bonnet	CuZn40Pb2 - CW617N - Piriç / Brass
3	Volan / Handwheel	Ebonit / Ebonite
4	Mil / Stem	CuZn40Pb2 - CW617N - Piriç / Brass
5	Klape / Disc	CuZn40Pb2 - CW617N - Piriç / Brass
6	Ölçüm Probu / Measurement probe	CuZn40Pb2 - CW617N - Piriç / Brass



Ölçüler Dimensions

Anma Basıncı Nominal Pressure	25 Bar						
Anma Çapı Nominal Diameter	DN	15	20	25	32	40	50
Vana Boyutları Valve Dimensions	G	1 / 2"	3 / 4"	1"	1 1 / 4"	1 1 / 2"	2"
	L	87	96	100	114	125	146
	H	105	106	125	128	143	144
	W	70					
Ağırlık Weight	Kg	0,550	0,600	0,840	1,050	1,410	1,950

Sfero Döküm / Ductile Iron

CDY-1030



Genel Özellikler / General Specifications

Çalışma Sıcaklık Aralığı / Working Temperature : -10 ... +110 °C (16 Bar)
"Pik Kullanım Sıcaklığıdır"

Standartlar / Standards

Sertifikalar / Certificates :

Tasarım / Design : TS 3148

Flanş Boyutları / Flange Dimensions : TS EN 1092-2 (PN 16)

Testler / Tests : TS EN 12266-1

Uygulamalar / Applications

Sıcak ve soğuk su sistemleri, basınçlı hava, asit ve alkali özelliği bulunmayan sıvı akışkanlar
Hot and cold water systems, compressed air, non-acidic and non-flammable liquid fluids

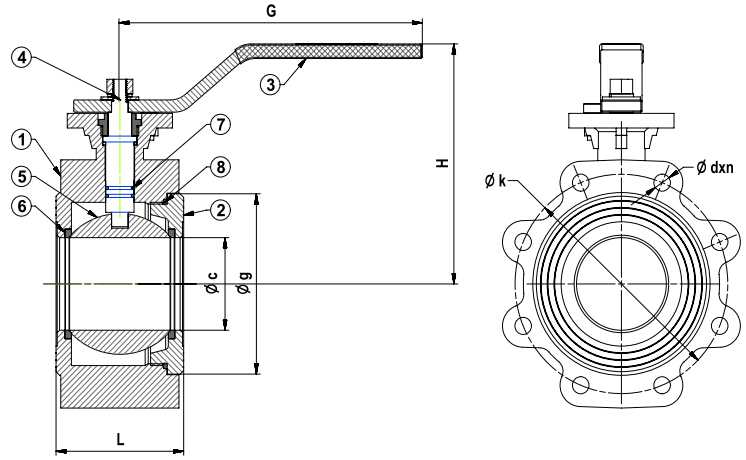

Malzeme Özellikleri Material Specifications

No	Parça Adı / Part Name	Malzeme / Material
1	Gövde / Body	GGG 40 - EN GJS 400-15 - Sfero Döküm / Ductile Iron
2	Kapak / Bonnet	GGG 40 - EN GJS 400-15 - Sfero Döküm / Ductile Iron
3	Kol / Lever	St37 - Çelik / Steel
4	Mil / Stem	X20Cr13 - AISI420 - Paslanmaz Çelik / Stainless Steel
5	Küre / Ball	Paslanmaz Çelik / Stainless Steel
6	Ringler / Seals	PTFE - Teflon
7	O-Ring	EPDM
8	O-Ring	EPDM



Ölçüler Dimensions

Anma Basıncı Nominal Pressure	16 Bar							
Anma Çapı Nominal Diameter	DN	65	80	100	125	150	200	
Vana Boyutları Valve Dimensions	L	77	93	108	160	183	235	
	G			255	335	400		
	H	140	151	197	223	255	285	
	k	145	160	180	210	240	295	
	g	115	130	150	184	214	266	
	c	50	65	80	100	125	150	
	dxn			M16x8			M20x8	M20x12
	Tepe Flanş* / Upper Flange			(ISO 5211) F07			(ISO 5211) F10	
Mil Karesi / Stem Square				□ 14	□ 17	□ 22		
Ağırlık Weight	Kg	5.7	8.4	11	18.7	34.2	71.2	

* Dişli kutusu ve aktüatör bağlantısına uygundur.
*(Suitable to fit with actuator and gear box).

Pik Döküm / Cast Iron

T-0510

Genel Özellikler / General Specifications

Çalışma Sıcaklık Aralığı / Working Temperature : -10 ... +110 °C (6 Bar)
"Pik Kullanım Sıcaklığıdır"

Standartlar / Standards

Tasarım / Design : TS 3148

Flanş Boyutları / Flange Dimensions : TS EN 1092-2 (PN 6)

Alından Alına Boyutlar / Face to Face Dimensions : TS EN 558 (Seri 14)

Testler / Tests : TS EN 12266-1

Uygulamalar / Applications

Sıcak ve soğuk su sistemleri, basınçlı hava, asit ve alkali özelliği bulunmayan sıvı akışkanlar
Hot and cold water systems, compressed air, non-acidic and non-flammable liquid fluids

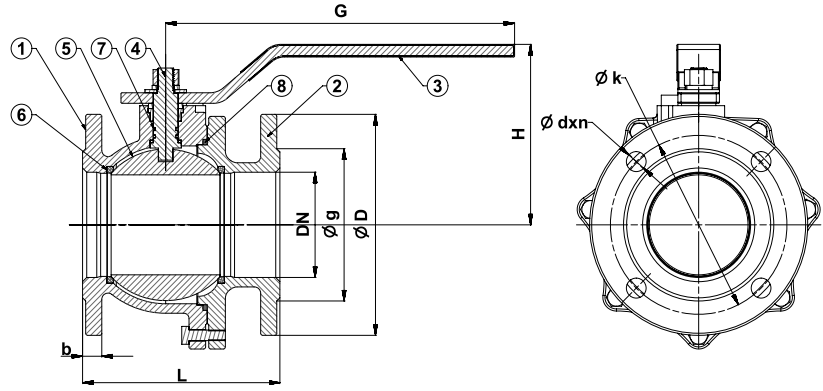

Malzeme Özellikleri Material Specifications

No	Parça Adı / Part Name	Malzeme / Material
1	Gövde / Body	GG 25 - EN GJL 250 - Pik Döküm / Cast Iron
2	Flanş / Flange	GG 25 - EN GJL 250 - Pik Döküm / Cast Iron
3	Kol / Lever	St37 - Çelik / Steel
4	Mil / Stem	X20Cr13 - AISI420 - Paslanmaz Çelik / Stainless Steel
5	Küre / Ball	Paslanmaz Çelik / Stainless Steel
6	Ringler / Seals	PTFE - Teflon
7	O-Ring	EPDM



Ölçüler Dimensions

Anma Basıncı Nominal Pressure	6 Bar						
Anma Çapı Nominal Diameter	DN	40	50	65	80	100	
Vana Boyutları Valve Dimensions	L	140	150	170	180	190	
	G	190	260		335		
	H	120	130	140	155	170	
	D	130	140	160	190	210	
	k	100	110	130	150	170	
	g	78	88	108	124	144	
	b	16				18	
	dxn	14x4				19x4	
Ağırlık Weight	Kg	5,5	6,7	9,8	14,5	18,5	

Tam Geçişli Küresel Vana (2 Parçalı PN 16)

Full Bore Ball Valve (2 Pcs PN 16)



Pik Döküm / Cast Iron

Sfero Döküm / Ductile Iron

T-0520

T-0525



Genel Özellikler / General Specifications

Çalışma Sıcaklık Aralığı / Working Temperature : -10... +110 ° C (16 Bar)
"Pik Kullanım Sıcaklığıdır"

Standartlar / Standards

Sertifikalar / Certificates :

Tasarım / Design : TS 3148

Flanş Bağlantı Ölçüleri / Flange Dimensions : TS EN 1092-2 (PN 16)

Alından Alına Boyutlar / Face to Face Dimensions : TS EN 558 (Seri 14)

Testler / Tests : TS EN 12266-1

Uygulamalar / Applications

Sıcak ve soğuk su sistemleri, basınçlı hava,
asit ve alkali özelliği bulunmayan sıvı akışkanlar
Hot and cold water systems, compressed air,
non-acidic and non-flammable liquid fluids

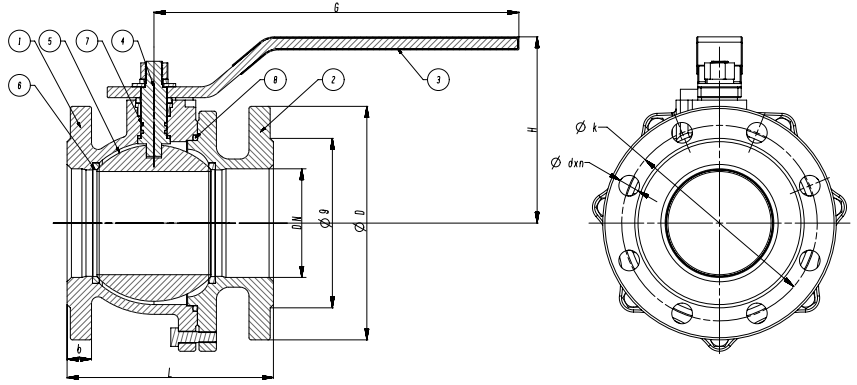

Malzeme Özellikleri Material Specifications

No	Parça Adı / Part Name	Malzeme / Material
1	Gövde / Body	GG 25 - EN G.JL 250 - Pik Döküm / Cast Iron (T-0520) GGG 40 - EN GJS 400-15 - Sfero Döküm / Ductile Iron (T-0525)
2	Flanş / Flange	GG 25 - EN G.JL 250 - Pik Döküm / Cast Iron (T-0520) GGG 40 - EN GJS 400-15 - Sfero Döküm / Ductile Iron (T-0525)
3	Kol / Lever	St37 - Çelik / Steel
4	Mil / Stem	X20Cr13 - AISI420 - Paslanmaz Çelik / Stainless Steel
5	Küre / Ball	Paslanmaz Çelik / Stainless Steel
6	Ringler / Seals	PTFE - Teflon
7	O-Ring / O-Ring	EPDM



Ölçüler Dimensions

Anma Basıncı Nominal Pressure	16 Bar									
Anma Çapı Nominal Diameter	DN	15*	20*	25*	32*	40	50	65	80	100
Vana Boyutları Valve Dimensions	L	115	120	125	130	140	150	170	180	190
	G	155			190		260		335	
	H	105			110	120	130	140	155	170
	D	95	105	115	140	150	165	185	200	220
	k	65	75	85	100	110	125	145	160	180
	g	46	56	65	76	84	99	118	132	156
	b	14	16		18		20		22	24
dxn	14x4			19x4				19x8		
Ağırlık Weight	kg	2.35	2.85	3.35	5.35	6.9	9.2	11.7	17.55	23.9

*Sfero Döküm / Ductile Iron

Tam Geçişli Küresel Vana (2 Parçalı PN 16) Full Bore Ball Valve (2 Pcs PN 16)



Pik Döküm / Cast Iron

Sfero Döküm / Ductile Iron

T-0540

T-0545

Genel Özellikler / General Specifications

Çalışma Sıcaklık Aralığı / Working Temperature : -10 ... +110 °C (16 Bar)
"Pik Kullanım Sıcaklığıdır"

Standartlar / Standards

Sertifikalar / Certificates :

Tasarım / Design : TS 3148

Flanş Boyutları / Flange Dimensions : TS EN 1092-2 (PN 16)

Alından Alına Boyutlar / Face to Face Dimensions : TS EN 558 (Seri 15)

Testler / Tests : TS EN 12266-1

Uygulamalar / Applications

Sıcak ve soğuk su sistemleri, basınçlı hava, asit ve alkali özelliği bulunmayan sıvı akışkanlar
Hot and cold water systems, compressed air, non-acidic and non-flammable liquid fluids

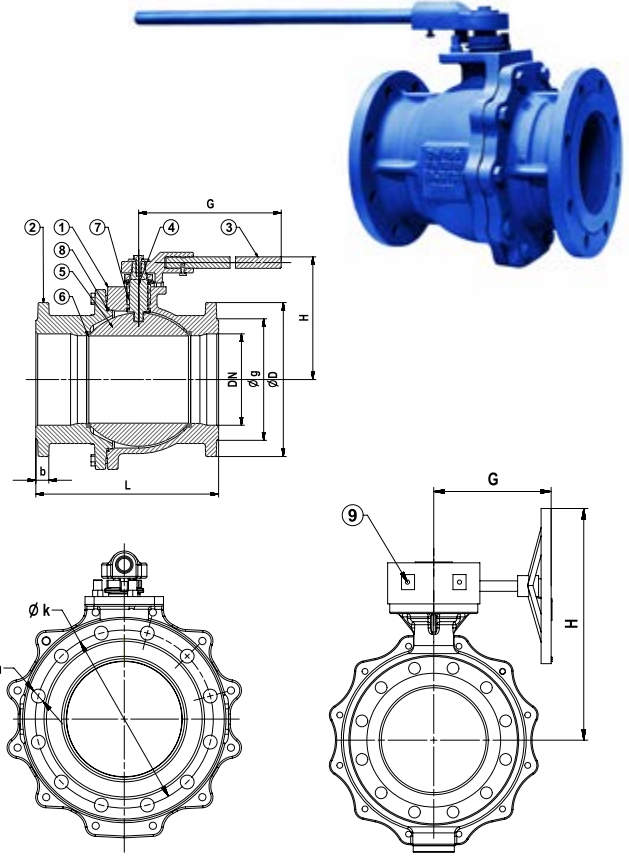

Malzeme Özellikleri Material Specifications

No	Parça Adı / Part Name	Malzeme / Material
1	Gövde / Body	GG 25 - EN GJL 250 - Pik Döküm / Cast Iron (T-0540) GGG 40 - EN GJS 400-15 - Sfero Döküm / Ductile Iron (T-0545)
2	Flanş / Flange	GG 25 - EN GJL 250 - Pik Döküm / Cast Iron (T-0540) GGG 40 - EN GJS 400-15 - Sfero Döküm / Ductile Iron (T-0545)
3	Kol / Lever	St37 - Çelik / Steel
4	Mil / Stem	X20Cr13 - AISI420 - Paslanmaz Çelik / Stainless Steel
5	Küre / Ball	Paslanmaz Çelik / Stainless Steel
6	Ringler / Seals	PTFE - Teflon
7	Salmastra / Packing	PTFE - Teflon
8	O-Ring	EPDM
9	Dişli Kutusu / Gear Box	GG 25 - EN GJL 250 - Pik Döküm / Cast Iron



Ölçüler Dimensions

Anma Basıncı Nominal Pressure	16 Bar					
Anma Çapı Nominal Diameter	DN	125	150	200*	250**	300***
Vana Boyutları Valve Dimensions	L	325	350	400	450	500
	G	335	700		280	
	H	190	250	280	555	
	D	250	285	340	405	460
	k	210	240	295	355	410
	g	184	211	266	319	370
	b	26		19		27
dxn	19x8	23x8	23x12	28x12		
Ağırlık Weight	Kg	41,4	70,2	81,5	180,5	203

* DN 200-250-300 çapları sfero dökümlüdür. / DN 200-250-300 dimensions are ductile iron.

** DN 250-300 çapları dişli kutuludur. / DN 250-300 dimensions are with a gearbox.

*** DN 300 çapı redüksiyon geçişlidir. / DN 300 dimensions is reduced bore.

Pik Döküm / Cast Iron

T-0530

Genel Özellikler / General Specifications

Çalışma Sıcaklık Aralığı / Working Temperature : -10 ... +110 °C (16 Bar)

"Pik Kullanım Sıcaklığıdır"

Standartlar / Standards

Sertifikalar / Certificates :

Tasarım / Design : TS 3148

Flanş Boyutları / Flange Dimensions : TS EN 1092-2 (PN 16)

Alından Alına Boyutlar / Face to Face Dimensions : DN 15 - 125 TS

EN 558 (Seri 1) DN 150 - 200 TS EN 558 (Seri 27)

Testler / Tests : TS EN 12266-1

Uygulamalar / Applications

Sıcak ve soğuk su sistemleri, basınçlı hava, asit ve alkali özelliği bulunmayan sıvı akışkanlar
Hot and cold water systems, compressed air, non-acidic and non-flammable liquid fluids

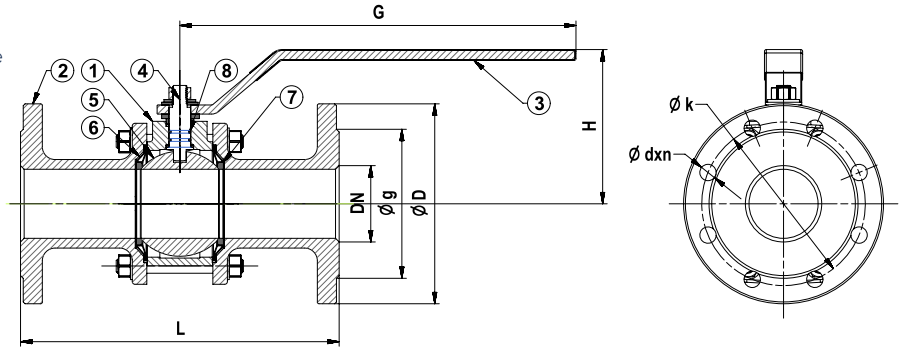

Malzeme Özellikleri Material Specifications

No	Parça Adı / Part Name	Malzeme / Material
1	Gövde / Body	GG 25 - EN GJL 250 - Pik Döküm / Cast Iron
2	Flanş / Flange	GG 25 - EN GJL 250 - Pik Döküm / Cast Iron
3	Kol / Lever	St37 - Çelik / Steel
4	Mil / Stem	X20Cr13 - AISI420 - Paslanmaz Çelik / Stainless Steel
5	Küre / Ball	Paslanmaz Çelik / Stainless Steel
6	Tabak Yaylar / Spring Seals	Paslanmaz Çelik + PTFE - Teflon / Stainless Steel + Teflon
7	Ringler / Seals	PTFE - Teflon
8	O-Ring	EPDM



Ölçüler Dimensions

Anma Basıncı Nominal Pressure	16 Bar													
Anma Çapı Nominal Diameter	DN	15	20	25	32	40	50	65	80	100	125	150	200	
Vana Boyutları Valve Dimensions	L	130	150	160	180	200	230	290	310	350	400	350	550	
	G	155			190			260		335			700	
	H	105			110	120	130	140	155	170	190	245	280	
	D	95	105	115	140	150	165	185	200	220	250	285	340	
	k	65	75	85	100	110	125	145	160	180	210	240	295	
	g	46	56	65	76	84	99	118	132	156	184	211	266	
	b	14	16		18			20		22	24	26		30
	dxn	14x4			19x4				19x8			23x8	23x12	
Ağırlık Weight	Kg	2.3	3.8	4	6.5	8.4	13.5	20	27	40	63	82.5	116	

Sfero Döküm / Ductile Iron

T-0560



Genel Özellikler / General Specifications

Çalışma Sıcaklık Aralığı / Working Temperature : -10 ... +110 °C (16 Bar)
"Pik Kullanım Sıcaklığıdır"

Standartlar / Standards

Sertifikalar / Certificates :

Tasarım / Design : TS 3148, EN ISO 17292

Diş Standardı / Thread Standard : EN ISO 228-1

Alından Alına Boyutlar / Face to Face Dimensions : TS 3148 / 1

Testler / Tests : TS EN 12266-1

Uygulamalar / Applications

Sıcak ve soğuk su sistemleri, basınçlı hava,
asit ve alkali özelliği bulunmayan sıvı akışkanlar
Hot and cold water systems, compressed air,
non-acidic and non-flammable liquid fluids

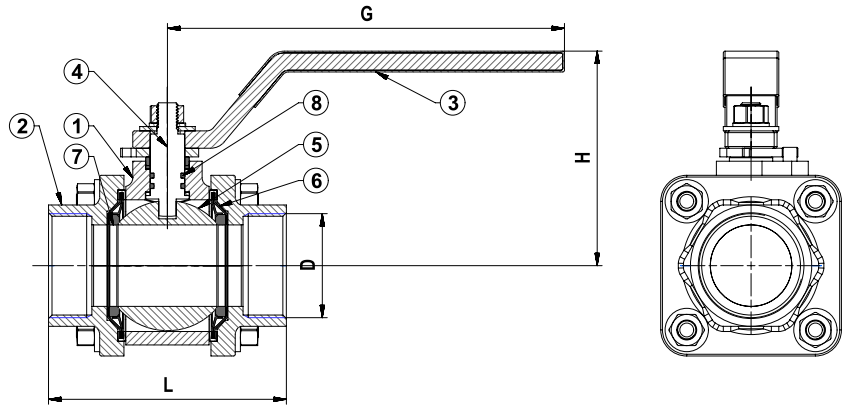

Malzeme Özellikleri Material Specifications

No	Parça Adı / Part Name	Malzeme / Material
1	Gövde / Body	GGG 40 - EN GJS 400-15 - Sfero Döküm / Ductile Iron
2	Flanş / Flange	GGG 40 - EN GJS 400-15 - Sfero Döküm / Ductile Iron
3	Kol / Lever	St37 - Çelik / Steel
4	Mil / Stem	X20Cr13 - AISI420 - Paslanmaz Çelik / Stainless Steel
5	Küre / Ball	Paslanmaz Çelik / Stainless Steel
6	Tabak Yayar / Spring Seals	Paslanmaz Çelik + PTFE - Teflon / Stainless Steel + Teflon
7	Ringler / Seals	PTFE - Teflon
8	O-Ring	EPDM



Ölçüler Dimensions

Anma Basıncı Nominal Pressure	16 Bar							
Anma Çapı Nominal Diameter	DN	15	20	25	32	40	50	65*
Vana Boyutları Valve Dimensions	D	1 / 2"	3 / 4"	1"	1 1 / 4"	1 1 / 2"	2"	2 1 / 2"
	L	75	80	90	110	120	140	155
	G	155			190		260	260
	H	105			110	120	130	140
Ağırlık Weight	Kg	0.6	1	1.5	2.4	4.4	7.5	8.2

* İki parçalıdır.
*(Two piece)

Sfero Döküm / Ductile Iron

T-0710

Genel Özellikler / General Specifications

Çalışma Sıcaklık Aralığı / Working Temperature : -10 ... +60 °C (25 Bar)

Standartlar / Standards

Sertifikalar / Certificates :

Tasarım / Design : TS 9809

Flanş Boyutları / Flange Dimensions : TS EN 1092-2

Alından Alına Boyutlar / Face to Face Dimensions : TS EN 558 (Seri 26)

Testler / Tests : TS EN 12266-1, TS EN 9809

Uygulamalar / Applications

Basıncı gazlar, sıvı yakıtlar, doğal gaz ve LPG

Pressured gases, liquid fuels, natural gas and LPG

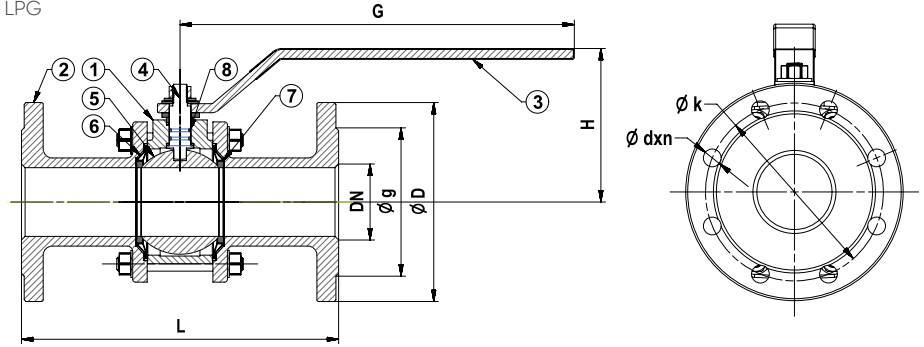

Malzeme Özellikleri Material Specifications

No	Parça Adı / Part Name	Malzeme / Material
1	Gövde / Body	GGG 40-ENGJS 400-15-Sfero Döküm / Ductile Iron
2	Flanş / Flange	GGG 40-ENGJS 400-15-Sfero Döküm / Ductile Iron
3	Kol / Lever	St37 - Çelik / Steel
4	Mil / Stem	X20Cr13 - AISI420 - Paslanmaz Çelik / Stainless Steel
5	Küre / Ball	Paslanmaz Çelik / Stainless Steel
6	Tabak Yaylar / Spring Seals	X5CrNi18 10 - AISI304 - Paslanmaz Çelik + PTFE - Teflon / Stainless Steel + PTFE - Teflon
7	Ringler / Seals	PTFE - Teflon
8	O-Ring	EPDM



Ölçüler Dimensions

Anma Basıncı Nominal Pressure		25 Bar					
Anma Çapı Nominal Diameter	DN	65	80	100	125	150	200
Vana Boyutları Valve Dimensions	L	290	310	350	400	450	550
	G	260	335			700	
	H	140	155	170	190	245	280
	D	185	200	220	270	300	360
	k	145	160	180	220	250	310
	g	118	132	156	184	211	274
	b	20	22	24	26	28	30
dxn	19x4	19x8		28x8		28x12	
Ağırlık Weight	Kg	14,9	21,3	32,8	62,4	96,8	116

Pik Döküm / Cast Iron

T-1320



Genel Özellikler / General Specifications

Çalışma Sıcaklık Aralığı / Working Temperature : -10 ... +110 °C 2,5 / 4 / 10 / (16 Bar)

Standartlar / Standards

Sertifikalar / Certificates :

Tasarım / Design : TS EN 1171

Flanş Boyutları / Flange Dimensions : TS EN 1092-2 (PN 10)

Alından Alına Boyutlar / Face to Face Dimensions : TS EN 558 (Seri 14)

Testler / Tests : TS EN 12266-1

Uygulamalar / Applications

Sıcak ve soğuk su sistemleri, asit ve alkali özelliği bulunmayan sıvı akışkanlar
Hot and cold water systems, non-acidic and non-flammable liquid fluids

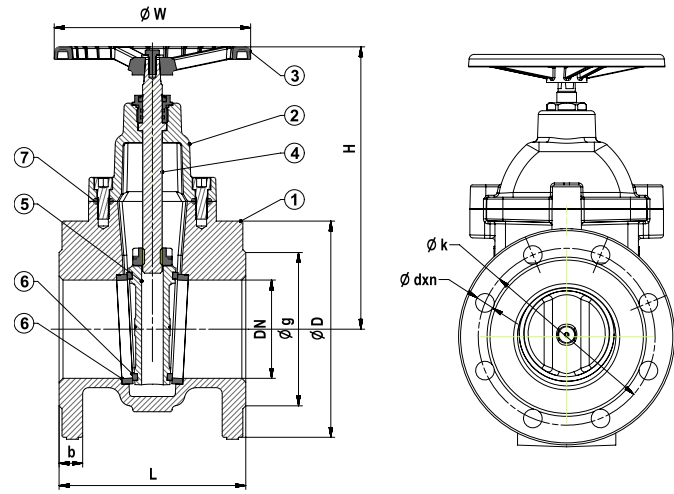

Malzeme Özellikleri Material Specifications

No	Parça Adı / Part Name	Malzeme / Material
1	Gövde / Body	GG 25 - EN GJL 250 - Pik Döküm / Cast Iron (T-1320)
2	Kapak / Bonnet	GG 25 - EN GJL 250 - Pik Döküm / Cast Iron (T-1320)
3	Volan / Handwheel	GG 25 - EN GJL 250 - Pik Döküm / Cast Iron
4	Mil / Stem	X20Cr13 - AISI420 - Paslanmaz Çelik / Stainless Steel
5	Sürgü / Wedge	GGG 40 - EN GJS 400-15 - Sfero Döküm / Ductile Iron
6	Sitler / Seats	CuZn40Pb2 - CW617N - Pirinç - Paslanmaz Çelik - Bronz / Brass - Stainless Steel - Bronze
7	Conta / Gasket	EPDM - NBR



Ölçüler Dimensions

Anma Basıncı Nominal Pressure		10 Bar						6 Bar			4 Bar			2,5 Bar	
Anma Çapı Nominal Diameter	DN	40	50	65	80	100	125	150	200	250	300	350	400	500	600
Boyutlar Dimensions	L	140	150	170	180	190	200	210	230	250	270	290	310	350	390
	H	170	180	230	245	265	355	400	490	615	700	835	910	1135	1300
	W	160				200	250		315			400		500	
	D	150	165	185	200	220	250	285	340	395	445	505	565	670	780
	k	110	125	145	160	180	210	240	295	350	400	460	515	620	725
	g	84	99	118	132	156	184	211	266	319	370	429	480	582	682
	b	18	20		22	24	26			28		30	32	34	36
	dxn	19x4			19x8			23x8		23x12		23x16	28x16	28x20	31x20
Ağırlık Weight	Kg	9	10	15	17	23	37	45	80	123	166	225	368	460	680

Pik Döküm / Ductile Iron

Sfero Döküm/ Ductile Iron

T-1430

T-1435



Genel Özellikler / General Specifications

Çalışma Sıcaklık Aralığı / Working Temperature : -10 ... +110 °C (16 Bar)
"Pik Kullanım Sıcaklığıdır"

Standartlar / Standards

Sertifikalar / Certificates :
Tasarım / Design : TS EN 1171
Flanş Boyutları / Flange Dimensions : TS EN 1092-2 (PN 16)
Alından Alına Boyutlar / Face to Face Dimensions : TS EN 558 (Seri 14)
Testler / Tests : TS EN 12266-1

Uygulamalar / Applications

Sıcak ve soğuk su sistemleri,
asit ve alkali özelliği bulunmayan sıvı akışkanlar
Hot and cold water systems, non-acidic and
non-flammable liquid fluids

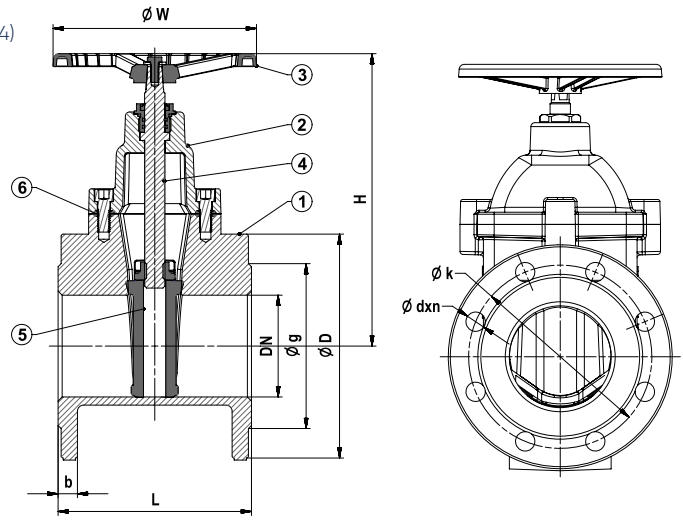

Malzeme Özellikleri Material Specifications

No	Parça Adı / Part Name	Malzeme / Material
1	Gövde / Body	GG 25 - EN G.JL 250 - Pik Döküm / Cast Iron (T-1430) DN 40-300 GGG 40 - EN GJS 400-15 - Sfero Döküm / Ductile Iron (T-1435)
2	Kapak / Bonnet	GG 25 - EN G.JL 250 - Pik Döküm / Cast Iron (T-1430) DN 40-300 GGG 40 - EN GJS 400-15 - Sfero Döküm / Ductile Iron (T-1435)
3	Volan / Handwheel	GG 25 - EN G.JL 250 - Pik Döküm / Cast Iron
4	Mil / Stem	X20Cr13 - AISI420 - Paslanmaz Çelik / Stainless Steel
5	Sürgü / Wedge	GGG 40 - EN GJS 400-15 - Sfero Döküm + Kauçuk Kaplı / Ductile Iron + Rubber Coated
6	Conta / Gasket	EPDM - NBR



Ölçüler Dimensions

Anma Basıncı Nominal Pressure	16 Bar														
Anma Çapı Nominal Diameter	DN	40	50	65	80	100	125	150	200	250	300	350*	400*	500*	600*
Vana Boyutları Valve Dimensions	L	140	150	170	180	190	200	210	230	250	270	290	310	350	390
	H	170	180	230	245	265	355	400	490	615	700	835	910	1120	1330
	W	160				200	250		315			400		500	
	D	150	165	185	200	220	250	285	340	405	460	520	580	715	840
	k	110	125	145	160	180	210	240	295	355	410	470	525	650	770
	g	84	99	118	132	156	184	211	266	319	370	429	480	609	720
	b	18	20		22	24	26		30	32		36	38	42	48
	dxn	19x4			19x8			23x8	23X12	28x12		28x16	31x16	34x20	37x20
Ağırlık Weight	Kg	9	10	15	17	23	37	45	80	123	166	200	310	370	620

* Sfero Döküm / Ductile Iron

Sfero Döküm / Ductile Iron

T-1437



Genel Özellikler / General Specifications

Çalışma Sıcaklık Aralığı / Working Temperature : -10 ... +110 °C (16 Bar)
"Pik Kullanım Sıcaklığıdır"

Standartlar / Standards

Sertifikalar / Certificates :
Tasarım / Design : TS EN 1171
Flanş Boyutları / Flange Dimensions : TS EN 1092-2 (PN 16)
Alından Alına Boyutlar / Face to Face Dimensions : TS EN 558 (Seri 14)
Testler / Tests : TS EN 12266-1

Uygulamalar / Applications

Sıcak ve soğuk su sistemleri,
asit ve alkali özelliği bulunmayan sıvı akışkanlar
Hot and cold water systems, non-acidic and
non-flammable liquid fluids

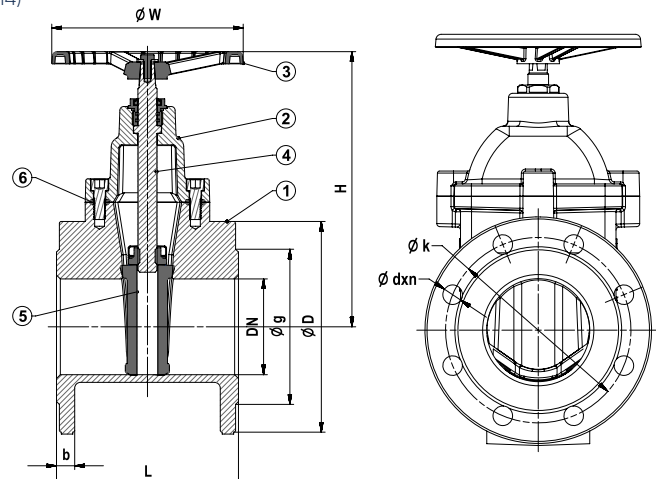

Malzeme Özellikleri Material Specifications

No	Parça Adı / Part Name	Malzeme / Material
1	Gövde / Body	Body GGG 40 - EN GJS 400-15 - Sfero Döküm / Ductile Iron
2	Kapak / Bonnet	Bonnet GGG 40 - EN GJS 400-15 - Sfero Döküm / Ductile Iron
3	Volan / Handwheel	GG 25 - EN GJL 250 - PİK Döküm / Cast Iron
4	Mil / Stem	X20Cr13 - AISI420 - Paslanmaz Çelik / Stainless Steel
5	Sürgü / Wedge	GGG 40 - EN GJS 400-15 - Sfero Döküm + Kauçuk Kaplı / Ductile Iron + Rubber Coated
6	Conta / Gasket	EPDM - NBR



Ölçüler Dimensions

Anma Basıncı Nominal Pressure	16 Bar										
Anma Çapı Nominal Diameter	DN	40	50	65	80	100	125	150	200	250	300
Vana Boyutları Valve Dimensions	L	140	150	170	180	190	200	210	230	250	270
	H	170	180	230	245	265	355	400	490	615	700
	W	160				200	250		315		
	D	150	165	185	200	220	250	285	340	405	460
	k	110	125	145	160	180	210	240	295	355	410
	g	84	99	118	132	156	184	211	266	319	370
	b	18	20		22	24	26		30	32	
	dxn	19x4				19x8			23x8	23x12	28x12
Ağırlık Weight	Kg	9	10	15	17	23	37	45	80	123	166

* Boya ve conta malzemeleri WRAS onaylıdır. / Paint and gasket materials are WRAS approved.

Pik Döküm / Cast Iron

Sfero Döküm / Ductile Iron

T-1440

T-1445



Genel Özellikler / General Specifications

Çalışma Sıcaklık Aralığı / Working Temperature : -10 ... +110 °C (16 Bar)
"Pik Kullanım Sıcaklığıdır"

Standartlar / Standards

Sertifikalar / Certificates :

Tasarım / Design : TS EN 1171

Flanş Boyutları / Flange Dimensions : TS EN 1092-2 (PN 16)

Alından Alına Boyutlar / Face to Face Dimensions : TS EN 558 (Seri 15)

Testler / Tests : TS EN 12266-1

Uygulamalar / Applications

Sıcak ve soğuk su sistemleri, asit ve alkali özelliği bulunmayan sıvı akışkanlar
Hot and cold water systems, non-acidic and non-flammable liquid fluids

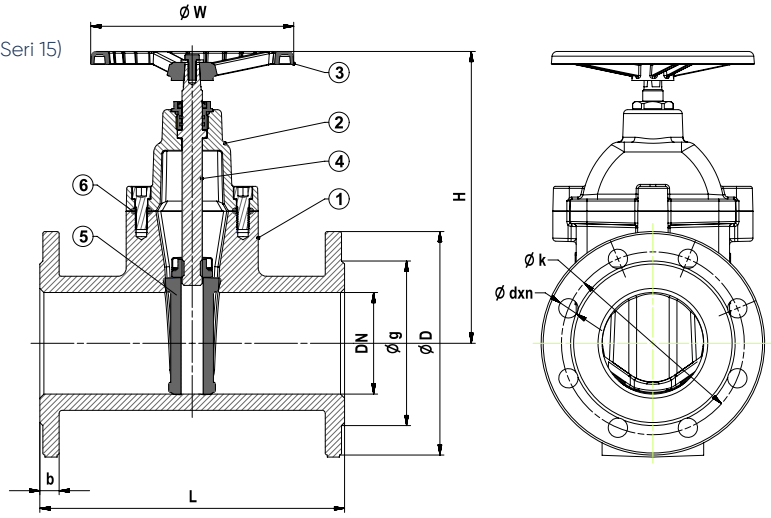

Malzeme Özellikleri Material Specifications

No	Parça Adı / Part Name	Malzeme / Material
1	Gövde / Body	GG 25 - EN G.JL 250 - Pik Döküm / Cast Iron (T-1440) DN 40-300 GGG 40 - EN GJS 400-15 - Sfero Döküm / Ductile Iron (T-1445)
2	Kapak / Bonnet	GG 25 - EN G.JL 250 - Pik Döküm / Cast Iron (T-1440) DN 40-300 GGG 40 - EN GJS 400-15 - Sfero Döküm / Ductile Iron (T-1445)
3	Volan / Handwheel	GG 25 - EN G.JL 250 - Pik Döküm / Cast Iron
4	Mil / Stem	X20Cr13 - AISI420 - Paslanmaz Çelik / Stainless Steel
5	Sürgü / Wedge	GGG 40 - EN GJS 400-15 - Sfero Döküm + Kauçuk Kaplı / Ductile Iron + Rubber Coated
6	Conta / Gasket	EPDM - NBR



Ölçüler Dimensions

Anma Basıncı Nominal Pressure	16 Bar										
Anma Çapı Nominal Diameter	DN	40	50	65	80	100	125	150	200	250	300
Vana Boyutları Valve Dimensions	L	240	250	270	280	300	325	350	400	450	500
	H	170	180	230	245	265	355	400	490	615	700
	W	160			200		250		315		
	D	150	165	185	200	220	250	285	340	405	460
	k	110	125	145	160	180	210	240	295	355	410
	g	84	99	118	132	156	184	211	266	319	370
	b	18	20		22	24	26		30	32	
dxn	19x4			19x8			23x8	23x12	28x12		
Ağırlık Weight	Kg	12	13	20	22	30	48	59	104	160	216

Pik Döküm / Cast Iron

T-1410

Genel Özellikler / General Specifications

Çalışma Sıcaklık Aralığı / Working Temperature :

-10 ... +110 °C (2,5 / 4 / 10 Bar)

"Pik Kullanım Sıcaklığıdır"

Standartlar / Standards

Sertifikalar / Certificates :

Tasarım / Design : TS EN 1171

Flanş Boyutları / Flange Dimensions : TS EN 1092-2 (PN 10)

Alından Alına Boyutlar / Face to Face Dimensions : TS EN 558 (Seri 14)

Testler / Tests : TS EN 12266-1

Uygulamalar / Applications

Sıcak ve soğuk su sistemleri, gemi sanayi, yangın tesisatlarında

Hot and cold water systems, marine industry, fire fighting systems

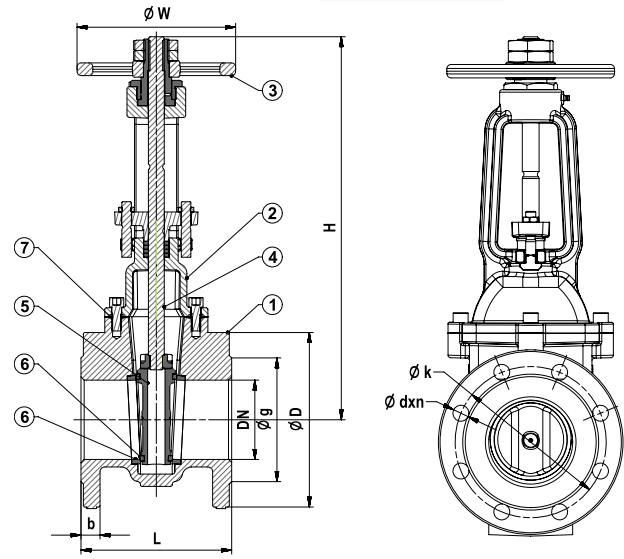

Malzeme Özellikleri Material Specifications

No	Parça Adı / Part Name	Malzeme / Material
1	Gövde / Body	GG 25 - EN GJL 250 - Pik Döküm / Cast Iron
2	Kapak / Bonnet	GG 25 - EN GJL 250 - Pik Döküm / Cast Iron
3	Volan / Handwheel	GG 25 - EN GJL 250 - Pik Döküm / Cast Iron
4	Mil / Stem	X20Cr13 - AISI420 - Paslanmaz Çelik / Stainless Steel
5	Sürgü / Wedge	GG 25 - EN GJL 250 - Pik Döküm / Cast Iron
6	Sitler / Seats	CuZn40Pb2 - CW617N - Piring - Paslanmaz Çelik - Bronz / Brass - Stainless Steel - Bronze
7	Conta / Gasket	EPDM - NBR



Ölçüler Dimensions

Anma Basıncı Nominal Pressure	10 Bar										
Anma Çapı Nominal Diameter	DN	40	50	65	80	100	125	150	200	250	300
Vana Boyutları Valve Dimensions	L	140	150	170	180	190	200	210	230	250	270
	H min	355	365	390	425	485	584	655	796	970	1110
	H max	405	430	475	525	605	735	835	1020	1245	1440
	W	200			250			315			400
	D	150	165	185	200	220	250	285	340	395	445
	k	110	125	145	160	180	210	240	295	350	400
	g	84	99	118	132	156	184	211	266	319	370
	b	18	20		22	24	26			28	
dxn	19x4			19x8			23x8			23x12	
Ağırlık Weight	Kg	11	15	20	24	30	44	58	106	158	232

Pik Döküm / Cast Iron

T-1370

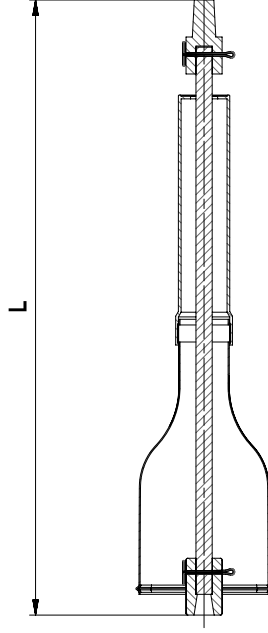
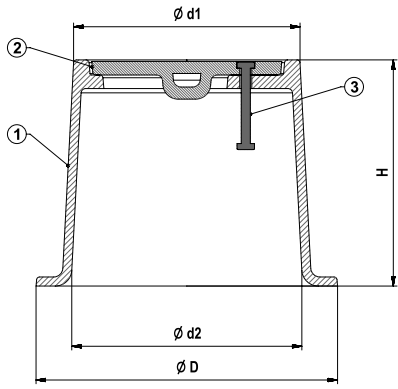

Malzeme Özellikleri Material Specifications

No	Para Adı / Part Name	Malzeme / Material
1	Kazan / Surface Box	GG 25 - EN GJL 250 - Pik Döküm / Cast Iron
2	Kapak / Bonnet	GG 25 - EN GJL 250 - Pik Döküm / Cast Iron
3	Pim / Pin	St37 - elik / Steel



Ölüler Dimensions

16 Bar					
Tip / Type	d1	d2	D	H	L
TİP 1 (DN 40-300)	150	150	200	150	600

Sfero Döküm / Ductile Iron

T-1130

Genel Özellikler / General Specifications

Çalışma Sıcaklık Aralığı / Working Temperature : -10 ... +110 °C (25 Bar)

"Pik Kullanım Sıcaklığıdır"

Standartlar / Standards

Sertifikalar / Certificates :

Tasarım / Design : TS EN 593

Bağlantı Boyutları / Connection Dimensions : TS EN 1092-2 (PN 25)

Testler / Tests : TS EN 12266-1

Uygulamalar / Applications

HVAC sistemleri, arıtma tesisleri, kağıt endüstrisi,
tatlı su tesisatları, deniz suyu
HVAC systems, water treatment systems,
paper industry, fresh water system, sea water



Malzeme Özellikleri Material Specifications

No	Parça Adı / Part Name	Malzeme / Material
1	Gövde / Body	GGG 40 - EN GJS 400-15 - Sfero Döküm / Ductile Iron
2	Klape + Kaplama / Clapper + Plated	GGG 40 - EN GJS 400-15 - Sfero Döküm + Kauçuk Kaplama / Ductile Iron + Rubber Coated
3	Kol / Lever	Alüminyum Enjeksiyon / Aluminum Injection
4	Üst Mil / Top Stem	X20Cr13 - AISI420 - Paslanmaz Çelik / Stainless Steel
5	Alt Mil / Bottom Stem	X20Cr13 - AISI420 - Paslanmaz Çelik / Stainless Steel
6	O-Ring	EPDM
7	Alın Contası / Face Gasket	EPDM
8	Mil Yatağı / Stem Bearing	Paslanmaz Çelik + Bronz / Stainless Steel + Bronze
9	Tapa / Plug	St 37 - Çelik / Steel



Ölçüler Dimensions

Anma Basıncı Nominal Pressure	25 Bar							
Anma Çapı Nominal Diameter	DN	65	80	100	125	150	200	
Vana Boyutları Valve Dimensions	L	46		52	56		60	
	E	210						355
	H1	93	103	113	135	149	175	
	H2	135	145	152	175	185	222	
	H	205	235	242	245	275	305	
	W	41,5	58	84	107	135	186	
	D	62	74	98,5	121,0	146	196	
	k	145	160	190	220	250	310	
	dxn	19x8		23x8	28x8		28x12	
	Tepe Flanş / Upper Flange	(ISO 5211) F05			(ISO 5211) F07		(ISO 5211) F10	
Mil Karesi / Stem Square	□11		□14	□17				
Ağırlık Weight	Kg	3,8	4,5	7,2	10,5	13	20,4	

Vanalarımız; dişli kutusu, pnömatik aktüatör ve elektrikli aktüatör bağlantısına uygundur.
Our valves; Suitable for gearbox, pneumatic actuator, and electrical actuator connections.

Kauçuk Kaplı Wafer Kelebek Vana (PN 16) Rubber Coated Wafer Butterfly Valve (PN 16)



Sfero Döküm + Nikel Kaplama
/ Ductile Iron + Nickel Plated

T-1135

Alüminyum Bronz
/ Aluminum Bronze

T-1137

Paslanmaz Çelik CF8-CF8M /
Stainless Steel

T-1136

Alüminyum Bronz
/ Aluminum Bronze

T-1138



Genel Özellikler / General Specifications

Çalışma Sıcaklık Aralığı / Working Temperature : -10 ... +110 °C (16 Bar)
"110 °C Kullanım Sıcaklığının Pik Noktasıdır."

"Peak Usage Temperature is 110°C"

Standartlar / Standards

Sertifikalar / Certificates :

Tasarım / Design : TS EN 593

Bağlantı Boyutları / Connection Dimensions : TS EN 1092-2 (PN 16)

Testler / Tests : TS EN 12266-1

Uygulamalar / Applications

HVAC sistemleri, arıtma tesisleri, kağıt endüstrisi,
tatlı su tesisatları, deniz suyu
HVAC systems, water treatment systems,
paper industry, fresh water system, sea water



Malzeme Özellikleri Material Specifications

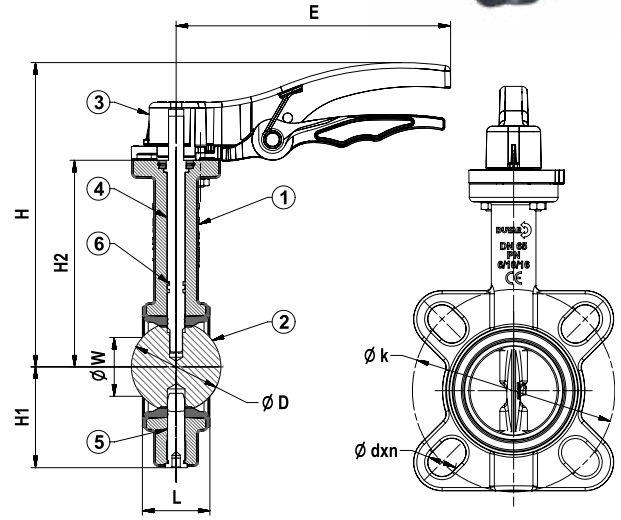

No	Parça Adı / Part Name	Malzeme / Material
1	Gövde / Body	GG 25 - EN GJL 250 - Pik Döküm + Kauçuk Kaplama / Cast Iron + Rubber Coated
2	Klape + Kaplama / Clapper + Plated	GGG 40 - EN GJS 400 -15 - Sfero Döküm + Nikel Kaplama - GX6CrNi189 - CF8-Paslanmaz Çelik / Ductile Iron + Nickel Plated - Cast Stainless Steel
3	Kol / Lever	Alüminyum Enjeksiyon / Aluminum Injection
4	Üst Mil / Top Stem	X20Cr13 - AISI420 - Paslanmaz Çelik / Stainless Steel
5	Alt Mil / Bottom Stem	X20Cr13 - AISI420 - Paslanmaz Çelik / Stainless Steel
6	O-Ring	EPDM



Ölçüler Dimensions

Anma Basıncı Nominal Pressure	16 Bar								
Anma Çapı Nominal Diameter	DN	50	65	80	100	125	150	200	
Vana Boyutları Valve Dimensions	L	43	46		52	56		60	
	E	210			265			355	
	H1	70	73	96	107	128	140	170	
	H2	140	150	160	182	196	200	240	
	H	210	220	230	250	265	285	325	
	W	31	45,9	62,2	90,6	110	145,6	193,9	
	D	53	65	79	104,5	123,5	156	203	
	k	125	145	160	180	210	240	295	
	dxn	19x4			19x8			23x8	23x12
	Tepe Flanş / Upper Flange	(ISO 5211) F05				(ISO 5211) F07			(ISO 5211) F10
Mil Karesi / Stem Square	□9			□14	□17				
Ağırlık Weight	Kg	3	3,5	4	6	7,5	10	14,5	

MODEL NO	KLAPE / CLAPPER	KAPLAMA / PLATED
	Sfero Döküm + Nikel Kaplama / Ductile Iron + Nickel Plated	EPDM
T-1136	Paslanmaz Çelik CF8-CF8M / Stainless Steel	EPDM
T-1137	Alüminyum Bronz / Aluminum Bronze	EPDM veya / or NBR
T-1138	Alüminyum Bronz / Aluminum Bronze	Viton

Vanalarımız; dişli kutusu, pnömatik aktüatör ve elektrisel aktüatör bağlantısına uygundur.
Our valves; Suitable for gearbox, pneumatic actuator, and electrical actuator connections.

Sfero Döküm / Ductile Iron

T-0910

Genel Özellikler / General Specifications

Çalışma Sıcaklık Aralığı / Working Temperature : -10 ... +110 °C (16
°C Kullanım Sıcaklığının Pik Noktasıdır."
"Peak Usage Temperature is 110°C"

Standartlar / Standards

Sertifikalar / Certificates :
Tasarım / Design : TS EN 593
Bağlantı Boyutları / Connection Dimensions : TS EN 1092-2
DN40-DN150: PN10/16 - DN200-DN450: PN16
Testler / Tests : TS EN 12266-1

Uygulamalar / Applications

HVAC Sistemleri, Arıtma Tesisleri,
Kağıt Endüstrisi, Tatlı Su Tesisatları
HVAC Systems, Water treatment systems,
Paper industry, Fresh water system



*DN500-600 çapları lug bağlantılıdır.
*DN500-600 diameters are lug connected.

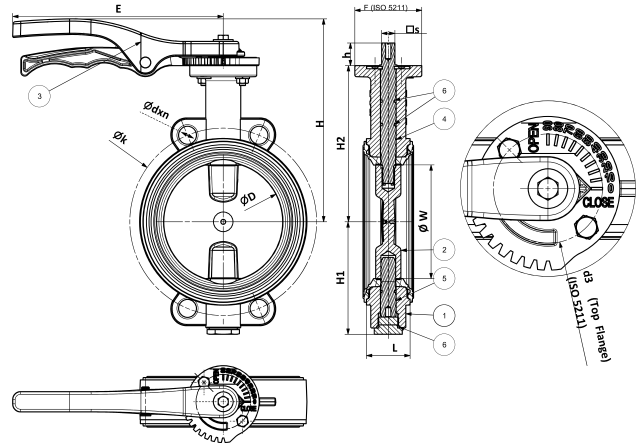

Malzeme Özellikleri Material Specifications

No	Parça Adı / Part Name	Malzeme / Material
1	Gövde / Body	GGG 40 - EN GJS 400-15 - Sfero Döküm / Ductile Iron
2	Klape + Kaplama / Clapper + Plated	GGG 40 - EN GJS 400-15 - Sfero Döküm + Nikel Kaplama / Ductile Iron + Nickel Plated
3	Kol / Lever	GGG 40 - EN GJS 400-15 - Sfero Döküm / Ductile Iron
4	Üst Mil / Top Stem	X20Cr13 - AISI420 - Paslanmaz Çelik / Stainless Steel
5	Alt Mil / Bottom Stem	X20Cr13 - AISI420 - Paslanmaz Çelik / Stainless Steel
6	O-Ring	EPDM



Ölçüler Dimensions

Anma Basıncı Nominal Pressure	16 Bar															
	DN	40	50	65	80	100	125	150	200	250	300	350	400	450	500*	600*
Anma Çapı Nominal Diameter	L	33	43	46	52	56	60	68	78	102	114	127	154			
Vana Boyutları Valve Dimensions	E	200			270			380			Dişli Kutuludur / With Gear Box					
	H1	69,5	73,5	80	100	112,5	133	144	178	209	240	280	310	340	375	440
	H2	118	140	150	160	181,5	196	200	240	280	320	360	400	420	460	520
	H	188	210	220	230	240	256	260	315	320	Dişli Kutuludur / With Gear Box					
	W	26,8	31	45,9	62,2	90,6	110	145,6	193,9	241,6	292,3	341,8	388,8	445,6	480,5	566,4
	D	42,5	53	65	79	104,5	123,5	156	203	251	302,5	334	402	445	492,5	582
	k	110	125	145	160	180	210	240	295	355	410	470	525	585	650	770
	dxn	19x4			19x8			23x8	23x12	28x12	28x16	31x16	31x20	34x20	37x20	
	Tepe Flaş / Upper Flange	F05			F07			F10			F16					
	d3	50			70			102			165					
□s Mil Karesi / Stem Square	□9			□14			□17			□22			□27		□36	
h	33	33	33	33	29	29	29	40	42,5	42,5	52,5	57	57	69,5	69,5	
Ağırlık Weight	Kg	2,5	3	3,5	4	6	7	9	15	23	27	49	90	110	150	242

Vanalarımız; dişli kutusu, pnömatik aktüatör ve elektrikli aktüatör bağlantısına uygundur.
Our valves; Suitable for gearbox, pneumatic actuator, and electrical actuator connections.

Sfero Döküm / Ductile Iron

T-0930

Genel Özellikler / General Specifications

Çalışma Sıcaklık Aralığı / Working Temperature : -10 ... +110 °C (16 Bar)
"110 °C Kullanım Sıcaklığının Pik Noktasıdır."
"Peak Usage Temperature is 110°C"

Standartlar / Standards

Sertifikalar / Certificates :
Tasarım / Design : TS EN 593
Bağlantı Boyutları / Connection Dimensions : TS EN 1092-2
DN40-DN150: PN10/16 - DN200-DN450: PN16
Testler / Tests : TS EN 12266-1

Uygulamalar / Applications

HVAC Sistemleri, Arıtma Tesisleri,
Kağıt Endüstrisi, Tatlı Su Tesisatları
HVAC Systems, Water treatment systems,
Paper industry, Fresh water system



*DN500-600 çapları lug bağlantılıdır.
*DN500-600 diameters are lug connected.

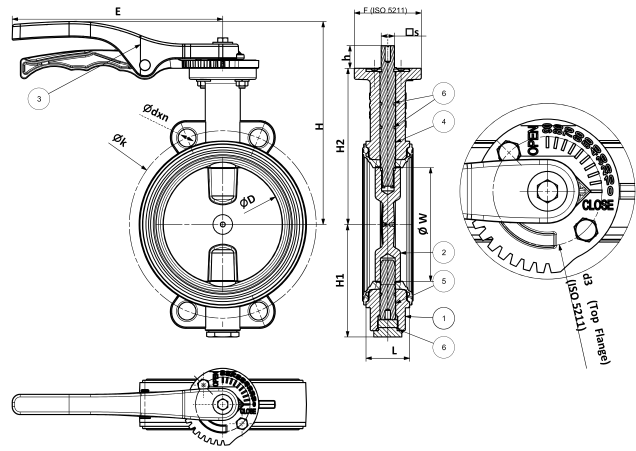

Malzeme Özellikleri Material Specifications

No	Parça Adı / Part Name	Malzeme / Material
1	Gövde / Body	GGG 40 - EN GJS 400-15 - Sfero Döküm / Ductile Iron
2	Klape / Clapper	G-X6CrNi189 - CF8 - Paslanmaz Çelik / Cast Stainless Steel
3	Kol / Lever	GGG 40 - EN GJS 400-15 - Sfero Döküm / Ductile Iron
4	Üst Mil / Top Stem	X20Cr13 - AISI420 - Paslanmaz Çelik / Stainless Steel
5	Alt Mil / Bottom Stem	X20Cr13 - AISI420 - Paslanmaz Çelik / Stainless Steel
6	O-Ring	EPDM



Ölçüler Dimensions

Anma Basıncı Nominal Pressure	16 Bar																
Anma Çapı Nominal Diameter	DN	40	50	65	80	100	125	150	200	250	300	350	400	450	500*	600*	
Vana Boyutları Valve Dimensions	L	33	43	46		52	56		60	68	78	102	114	127	154		
	E	200			270			380			Dişli Kutuludur / With Gear Box						
	H1	69,5	73,5	80	100	112,5	133	144	178	209	240	280	310	340	375	440	
	H2	118	140	150	160	181,5	196	200	240	280	320	360	400	420	460	520	
	H	188	210	220	230	240	256	260	315	320	Dişli Kutuludur / With Gear Box						
	W	26,8	31	45,9	62,2	90,6	110	145,6	193,9	241,6	292,3	341,8	388,8	445,6	480,5	566,4	
	D	42,5	53	65	79	104,5	123,5	156	203	251	302,5	334	402	445	492,5	582	
	k	110	125	145	160	180	210	240	295	355	410	470	525	585	650	770	
	dxn	19x4			19x8			23x8	23x12	28x12	28x16	31x16	31x20	34x20	37x20		
	Tepe Flanş / Upper Flange	F05				F07				F10				F16			
	d3	50				70				102				165			
□s Mil Karesi / Stem Square	□9				□14		□17			□22			□27		□36		
h	33	33	33	33	29	29	29	40	42,5	42,5	52,5	57	57	69,5	69,5		
Ağırlık Weight	Kg	2,5	3	3,5	4	6	7	9	15	23	27	49	90	110	150	242	

Vanalarımız; dişli kutusu, pnömatik aktüatör ve elektrikli aktüatör bağlantısına uygundur.
Our valves; Suitable for gearbox, pneumatic actuator, and electrical actuator connections.

Sfero Döküm / Ductile Iron

T-1010



Genel Özellikler / General Specifications

Çalışma Sıcaklık Aralığı / Working Temperature : -10 ... +110 °C (16 Bar)
"110 °C Kullanım Sıcaklığının PİK Noktasıdır."
"Peak Usage Temperature is 110°C"

Standartlar / Standards

Sertifikalar / Certificates :
Tasarım / Design : TS EN 593
Bağlantı Boyutları / Connection Dimensions : TS EN 1092-2
DN40-DN150: PN10/16 - DN200-DN600: PN16
Testler / Tests : TS EN 12266-1

Uygulamalar / Applications

HVAC Sistemleri, Arıtma Tesisleri,
Kağıt Endüstrisi, Tatlı Su Tesisatları
HVAC Systems, Water treatment systems,
Paper industry, Fresh water system

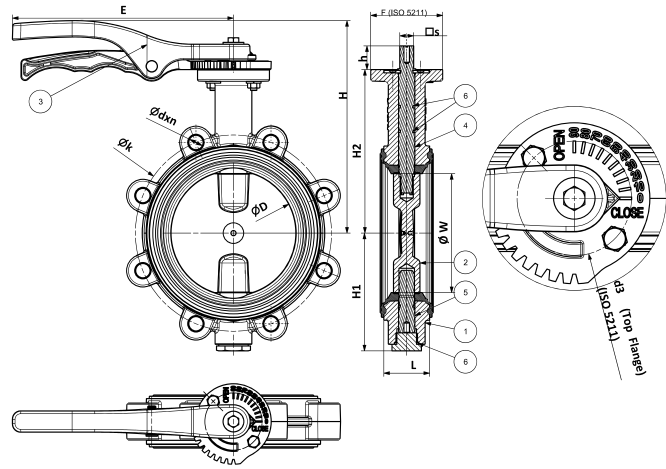

Malzeme Özellikleri Material Specifications

No	Parça Adı / Part Name	Malzeme / Material
1	Gövde / Body	GGG 40 - EN GJS 400-15 - Sfero Döküm / Ductile Iron
2	Klape + Kaplama / Clapper + Plated	GGG 40 - EN GJS 400-15 - Sfero Döküm + Nikel Kaplama / Ductile Iron + Nickel Plated
3	Kol / Lever	GGG 40 - EN GJS 400-15 - Sfero Döküm / Ductile Iron
4	Üst Mil / Top Stem	X20Cr13 - AISI420 - Paslanmaz Çelik / Stainless Steel
5	Alt Mil / Bottom Stem	X20Cr13 - AISI420 - Paslanmaz Çelik / Stainless Steel
6	O-Ring	EPDM



Ölçüler Dimensions

Anma Basıncı Nominal Pressure	16 Bar															
Anma Çapı Nominal Diameter	DN	40	50	65	80	100	125	150	200	250	300	350	400	450	500	600
Vana Boyutları Valve Dimensions	L	33	43	46		52	56		60	68	78	102	114	127	154	
	E	200			270			380			Dişli Kutuludur / With Gear Box					
	H1	69,5	73,5	80	100	112,5	133	144	178	209	240	280	310	340	375	440
	H2	118	140	150	160	181,5	196	200	240	280	320	360	400	420	460	520
	H	188	210	220	230	240	256	260	315	320	Dişli Kutuludur / With Gear Box					
	W	26,8	31	45,9	62,2	90,6	110	145,6	193,9	241,6	292,3	341,8	388,8	445,6	480,5	566,4
	D	42,5	53	65	79	104,5	123,5	156	203	251	302,5	334	402	445	492,5	582
	k	110	125	145	160	180	210	240	295	355	410	470	525	585	650	770
	dxn	19x4			19x8			23x8	23x12	28x12	28x16	31x16	31x20	34x20	37x20	
	Tepe Flanş / Upper Flange	F05				F07			F10				F16			
	d3	50				70			102				165			
	□s Mil Karesi / Stem Square	□9			□14		□17			□22			□27		□36	
h	33	33	33	33	29	29	29	40	42,5	42,5	52,5	57	57	69,5	69,5	
Ağırlık Weight	Kg	2,5	3	3,5	4	6	7	9	15	23	27	49	90	110	150	242

Vanalarımız; dişli kutusu, pnömatik aktüatör ve elektrikli aktüatör bağlantısına uygundur.
Our valves; Suitable for gearbox, pneumatic actuator, and electrical actuator connections.

Sfero Döküm / Ductile Iron

T-1030



Genel Özellikler / General Specifications

Çalışma Sıcaklık Aralığı / Working Temperature : -10 ... +110 °C (16 Bar)
"110 °C Kullanım Sıcaklığının Pik Noktasıdır."
"Peak Usage Temperature is 110°C"

Standartlar / Standards

Sertifikalar / Certificates :
Tasarım / Design : TS EN 593
Bağlantı Boyutları / Connection Dimensions : TS EN 1092-2
DN40-DN150: PN10/16 - DN200-DN600: PN16
Testler / Tests : TS EN 12266-1

Uygulamalar / Applications

HVAC Sistemleri, Arıtma Tesisleri,
Kağıt Endüstrisi, Tatlı Su Tesisatları
HVAC Systems, Water treatment systems,
Paper industry, Fresh water system

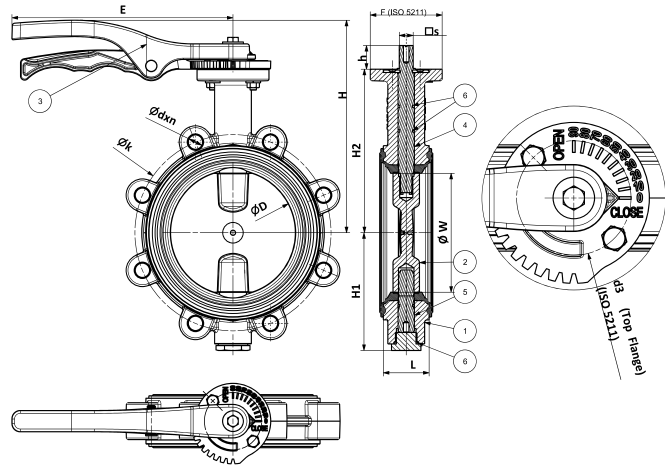

Malzeme Özellikleri Material Specifications

No	Parça Adı / Part Name	Malzeme / Material
1	Gövde / Body	GGG 40 - EN GJS 400-15 - Sfero Döküm / Ductile Iron
2	Klape / Clapper	G-X6CrNi189 - CF8 - Paslanmaz Çelik / Cast Stainless Steel
3	Kol / Lever	GGG 40 - EN GJS 400-15 - Sfero Döküm / Ductile Iron
4	Üst Mil / Top Stem	X20Cr13 - AISI420 - Paslanmaz Çelik / Stainless Steel
5	Alt Mil / Bottom Stem	X20Cr13 - AISI420 - Paslanmaz Çelik / Stainless Steel
6	O-Ring	EPDM



Ölçüler Dimensions

Anma Basıncı Nominal Pressure	16 Bar																
	DN	40	50	65	80	100	125	150	200	250	300	350	400	450	500	600	
Vana Boyutları Valve Dimensions	L	33	43	46		52	56		60	68	78	102	114	127	154		
	E	200			270			380			Dişli Kutuludur / With Gear Box						
	H1	69,5	73,5	80	100	112,5	133	144	178	209	240	280	310	340	375	440	
	H2	118	140	150	160	181,5	196	200	240	280	320	360	400	420	460	520	
	H	188	210	220	230	240	256	260	315	320	Dişli Kutuludur / With Gear Box						
	W	26,8	31	45,9	62,2	90,6	110	145,6	193,9	241,6	292,3	341,8	388,8	445,6	480,5	566,4	
	D	42,5	53	65	79	104,5	123,5	156	203	251	302,5	334	402	445	492,5	582	
	k	110	125	145	160	180	210	240	295	355	410	470	525	585	650	770	
	dxn	19x4			19x8			23x8	23x12	28x12	28x16	31x16	31x20	34x20	37x20		
	Tepe Flanş / Upper Flange	F05				F07				F10				F16			
	d3	50				70				102				165			
	□s Mil Karesi / Stem Square	□9				□14		□17			□22			□27		□36	
h	33	33	33	33	29	29	29	40	42,5	42,5	52,5	57	57	69,5	69,5		
Ağırlık Weight	Kg	2,5	3	3,5	4	6	7	9	15	23	27	49	90	110	150	242	

Vanalarımız; dişli kutusu, pnömatik aktüatör ve elektrikli aktüatör bağlantısına uygundur.
Our valves; Suitable for gearbox, pneumatic actuator, and electrical actuator connections.

Sfero Döküm / Ductile Iron

T-1150



Genel Özellikler / General Specifications

Ölçü / Dimensions : 2" - 8" / DN50 - DN200

Anma Basıncı / Nominal Pressure : 300 psi (21 bar)

Çalışma Sıcaklık Aralığı / Working Temperature : -10°C, +90°C
"Daha yüksek çalışma sıcaklığı talepleriniz için lütfen bize danışınız."
"Please consult us for your higher working temperature demands."

Standartlar / Standards

Tepe Flanşı / Top Flange : EN ISO 5211

Tasarım / Design : MSS SP 67

Yiv / Grooved Ends : ANSI AWWA C606

Testler / Tests : EN 12266-1

Uygulamalar / Applications

Bölgesel kontrol vanası veya kapatma vanası olarak tanımlanırlar. Mahal içi zonları birbirinden ayırmak (kontrol etmek) için su besleme hatları üzerinde kesme vanası olarak kullanılırlar. ISO EN 5211 standardına sahip olması sebebiyle dişli kutusu veya aktüatör ile çalıştırma opsiyonları vardır.

They are defined as local control valves or isolation valves. Generally, they are used in water feed lines as interruption valves in order to separate (to control) zones in the location. Due to its top flange design complying with ISO EN 5211, The valve can be operated with a gearbox or any actuator.

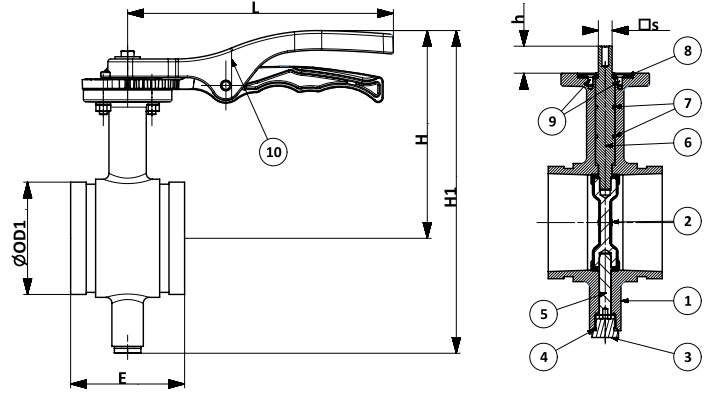

Malzeme Özellikleri Material Specifications

No	Parça Adı / Part Name	Malzeme / Material
1	Gövde Ekopsi Boyalı / Body	EN 1563 / Ductile Iron / Epoxy Coated
2	Klape / Clapper	Ductile Iron+EPDM / NBR / FKM
3	Tapa / Öring Nut	ST-40 JAN JAN ZINC COATED
4	O-Ring / Oring	EPDM / NBR / FKM
5	Alt Mil / Lower Stem	X20Cr13
6	Üst Mil / Upper Stem	X20Cr13
7	Öring / Oring	EPDM / NBR / FKM
8	Baskı Sacı / Preventing Plate	ST-37
9	Civata / Bolt	Steel Galvanized
10	Kelebek Vana Kol / Lever	Aluminium / Ductile Iron



Ölçüler Dimensions

Anma Basıncı Nominal Pressure	16 Bar							
Anma Çapı Nominal Diameter	DN	50	65	80	100	125	150	200
Vana Boyutları Valve Dimensions	ØD1	60.3	73	88.9	114.3	141.3	168.3	219.1
	ØD1*	60.3	76.1	88.9	114.3	139.7	165.1	219.1
	E	81	97	97	116	148	148	133
	H	151.5	157	167	174	202	216	251
	H1	244	254	274	291	340	368	430
	L	210	210	210	270	270	270	380
	h	32	32	32	28	28	28	40
	s	□9	□9	□9	□14	□17	□17	□17
"(ISO 5211) TEPE FLANŞ Gearbox Flange"	F5	F5	F5	F07	F07	F07	F10	

Not: Aksi belirtilmediği sürece vanalar ØD1* yiv ölçülerine göre üretilir.

Note: Unless otherwise stated the valves are produced according to ØD1* groove dimensions

Pik Döküm / Cast Iron

T-1210

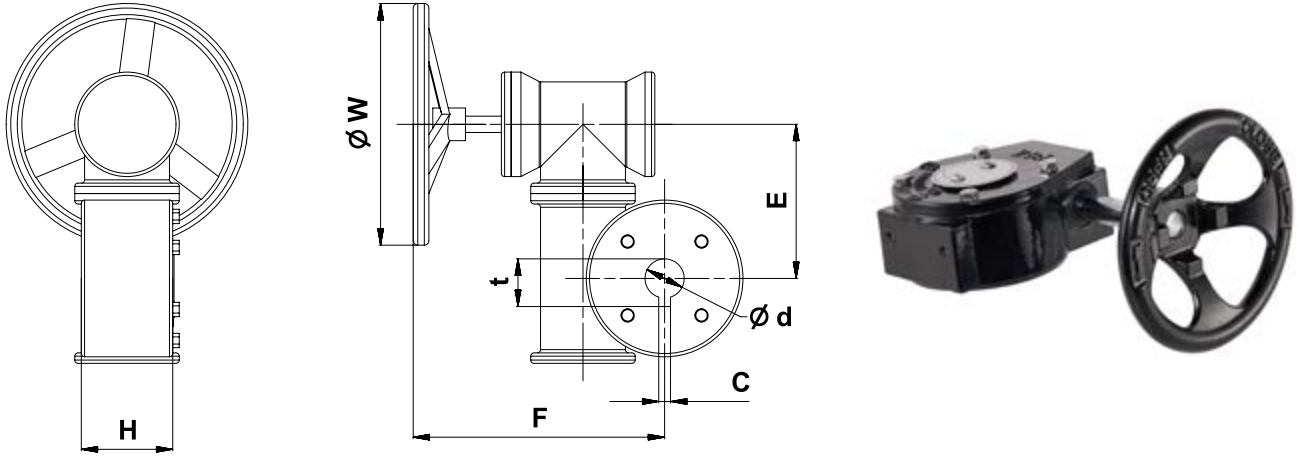





Vana Ölçüsü Valve Size		Tork Torque Nm	Tahvil Oranı Ratio	W	E	H	F	□A / Ød	C	t	Tepe Flanşı Upper Flange	Ağırlık Weight (Kg.)
DN mm	NPS mm											
40	1 1/2"	170	24:1	150	50	62	150	□9	/	/	(ISO 5211) F05	4.5
50	2"											
65	2 1/2"											
80	3"											
100	4"											
125	5"											
150	6"	750	30:1	300	70	80	220	□17	/	/	(ISO 5211) F07	7.5
200	8"											
250	10"											
300	12"											
350	14"	1200	50:1	300	70	80	220	□22	/	/	(ISO 5211) F10	14
400	16"											
450	18"											
500	20"	2500	80:1	360	95	105	217	□27	/	/	(ISO 5211) F16	65
500	20"											
600	24"	3000	352:1	360	185	120	210	Ø41,3	10	36.3	41.4	72
600	24"											
		4000	416:1	360	185	120	210	Ø50,8	16	55.1	44.6	72

DUYAR 
Since 1965

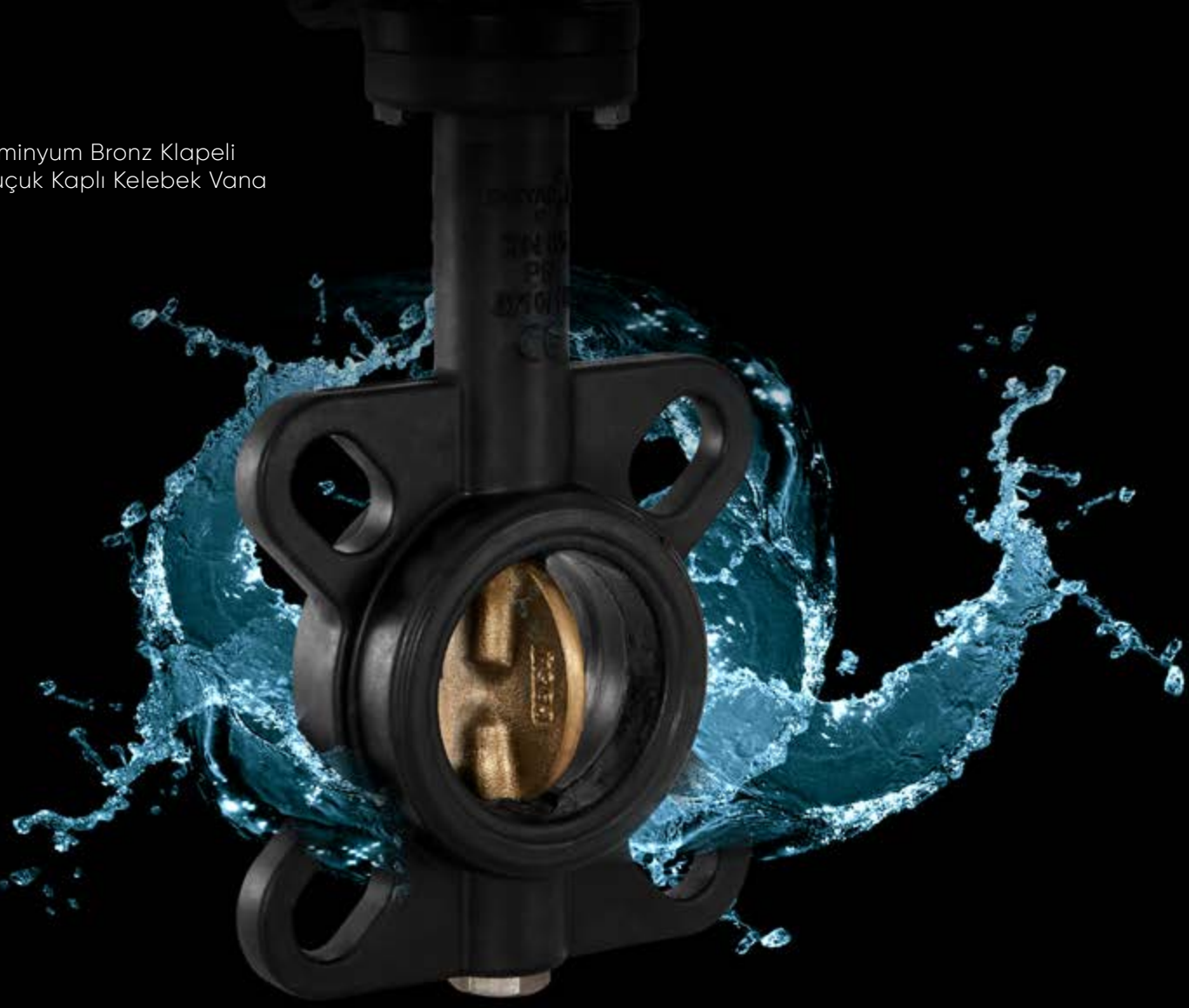
TUZA VE KOROZYONA DAYANIKLI

Alüminyum Bronz Klapeli
Kauçuk Kaplı Kelebek Vana



    /DuyarVana | Duyar.com

Pik Döküm / Cast Iron

Sfero Döküm / Ductile Iron

T-0110

T-0120

Genel Özellikler / General Specifications

Çalışma Sıcaklık Aralığı / Working Temperature : -10 ... +120 °C (16 Bar),
200 °C (13 Bar), 250 °C (11 Bar), 300 °C (10 Bar)

Standartlar / Standards

Sertifikalar / Certificates :

Tasarım / Design : TS EN 13789

Flanş Boyutları / Flange Dimensions : TS EN 1092-2 (PN 16)

Alından Alına Boyutlar / Face to Face Dimensions : TS EN 558 (Seri 1)

Testler / Tests : TS EN 12266-1



Uygulamalar / Applications

Sıcak ve soğuk su sistemleri, deniz suyu (sfero döküm), basınçlı hava, kızgın su, buhar, kızgın buhar, asit ve alkali özelliği bulunmayan sıvı akışkanlar
Hot and cold water systems, sea water (Ductile Iron), compressed air, superheated water, steam, superheated steam systems, non-acidic and non-flammable liquid fluids



Malzeme Özellikleri Material Specifications

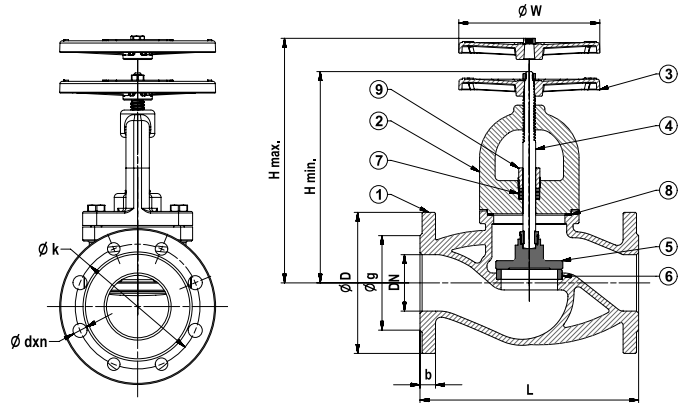

No	Parça Adı / Part Name	Malzeme / Material
1	Gövde / Body	GG 25 - EN GJL 250 - Pik Döküm / Cast Iron (T-0110) GGG 40 - EN GJS 400-15 - Sfero Döküm / Ductile Iron (T-0120)
2	Kapak / Bonnet	GG 25 - EN GJL 250 - Pik Döküm / Cast Iron (T-0110) GGG 40 - EN GJS 400-15 - Sfero Döküm / Ductile Iron (T-0120)
3	Volan / Handwheel	GG 25 - EN GJL 250 - Pik Döküm / Cast Iron (T-0110 T-0120)
4	Mil / Stem	X20Cr13 - AISI420 - Paslanmaz Çelik / Stainless Steel
5	Klape / Disc	DN 15-100, X20Cr13 - AISI420 - Paslanmaz Çelik / Stainless Steel DN 125-300, St 37 - Çelik + Paslanmaz Çelik / Steel + Stainless Steel
6	Sit / Seat	X5CrNi18 10 - AISI304 - Paslanmaz Çelik / Stainless Steel
7	Salmastra / Packing	Grafit / Graphite
8	Conta / Gasket	Grafit / Graphite
9	Salmastra Baskısı / Packing gland	CuZn40Pb2 - CW617N - Pirinç Dövme / Forced Brass



Ölçüler Dimensions

Anma Basıncı Nominal Pressure	16 Bar														10 Bar	
	DN	15	20	25	32	40	50	65	80	100	125	150	200	250	300	
Vana Boyutları Valve Dimensions	L	130	150	160	180	200	230	290	310	350	400	480	600	730	850	
	H min.	185	190	215	220	235	245	265	290	310	365	425	570	730	860	
	H max.	200		230	240	275	310		345	395	455	535	680	800	870	
	W	125			160			200		250	315		400	500		
	D	95	105	115	140	150	165	185	200	220	250	285	340	405	460	
	k	65	75	85	100	110	125	145	160	180	210	240	295	355	410	
	g	46	56	65	76	84	99	118	132	156	184	211	266	319	370	
	b	14	16		18			20		22	24	26		30	32	
	dxn	14x4			19x4				19x8			23x8	23x12	28x12		
Ağırlık Weight	Kg	4	5	6	8	10	14	21	29	42	63	89	155	259	357	

Çelik Döküm

T-0170

Genel Özellikler / General Specifications

Çalışma Sıcaklık Aralığı / Working Temperature : -20 ... +400°C (40 Bar),
150°C (35,2 Bar), 250°C (30,4 Bar), 300°C (26,7 Bar), 350°C (25,7 Bar), 400°C (23,8 Bar)

Standartlar / Standards

Sertifikalar / Certificates :
Tasarım / Design : TS EN 13789
Flanş Boyutları / Flange Dimensions : TS EN 1092-1 (PN 40)
Alından Alına Boyutlar / Face to Face Dimensions : TS EN 558 (Seri 1)
Testler / Tests : TS EN 12266-1

Uygulamalar / Applications

Sıcak ve soğuk su sistemleri, deniz suyu, basınçlı hava, kızgın su, buhar, kızgın buhar, asit ve alkali özelliği bulunmayan sıvı akışkanlar
Hot and cold water systems, sea water, compressed air, superheated water, steam, superheated steam systems, non-acidic and non-flammable liquid fluids

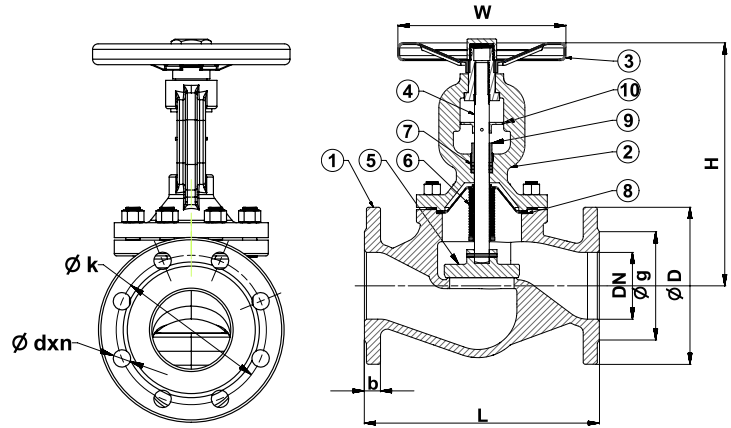

Malzeme Özellikleri Material Specifications

No	Parça Adı / Part Name	Malzeme / Material
1	Gövde / Body	GS-C 25 - GP240GH - Çelik Döküm / Cast Steel
2	Kapak / Bonnet	GS-C 25 - GP240GH - Çelik Döküm / Cast Steel
3	Volan / Handwheel	St37 - Çelik / Steel
4	Mil / Stem	X5CrNi18 10 - AISI304 - Paslanmaz Çelik / Stainless Steel
5	Klape / Disc	X5CrNi18 10 - AISI304 - Paslanmaz Çelik / Stainless Steel
6	Körük / Bellow	X5CrNi18 10 - AISI304 - Paslanmaz Çelik / Stainless Steel
7	Salmastra / Packing	Esnek Grafit Conta / Flexible Graphite Gasket
8	Conta / Gasket	Esnek Grafit Conta + Paslanmaz Çelik / Flexible Graphite Gasket + Stainless Steel
9	Salmastra Baskısı / Packing Gland	CuZn40Pb2 - CW617N - Piriç Dövme / Forced Brass
10	Seviye Göstergesi / Level Indicator	St37 - Çelik / Steel



Ölçüler Dimensions

Anma Basıncı Nominal Pressure	40 Bar													
Anma Çapı Nominal Diameter	DN	15	20	25	32	40	50	65	80	100	125	150	200	250
Vana Boyutları Valve Dimensions	L	130	150	160	180	200	230	290	310	350	400	480	600	730
	H	190		195	210	220	230	255	270	360	380	415	530	665
	W	140		160	180		200		250	280	300	350	400	450
	D	95	105	115	140	150	165	185	200	235	270	300	375	450
	k	65	75	85	100	110	125	145	160	190	220	250	320	385
	g	45	58	68	78	88	102	122	138	162	188	218	285	345
	b	16	18				20	22	24		26	28	34	38
	dxn	14x4			18x4			18x8		22x8	26x8		30x12	33x12
Ağırlık Weight	Kg.	4	4,5	5	8	10	13,5	20	25	45	60	98	171	340

Çelik Döküm / Cast Steel

T-0160

Genel Özellikler / General Specifications

Çalışma Sıcaklık Aralığı / Working Temperature : -20 ... +400 °C (16 Bar)

Standartlar / Standards

Sertifikalar / Certificates :

Tasarım / Design : TS EN 13789

Flanş Boyutları / Flange Dimensions : TS EN 1092-1 (PN 16)

Alından Alına Boyutlar / Face to Face Dimensions : TS EN 558 (Seri 1)

Testler / Tests : TS EN 12266-1



Uygulamalar / Applications

Sıcak ve soğuk su sistemleri, deniz suyu, basınçlı hava, kızgın su, buhar, kızgın buhar, asit ve alkali özelliği bulunmayan sıvı akışkanlar
Hot and cold water systems, sea water, compressed air, superheated water, steam, superheated steam systems, non-acidic and non-flammable liquid fluids



Malzeme Özellikleri Material Specifications

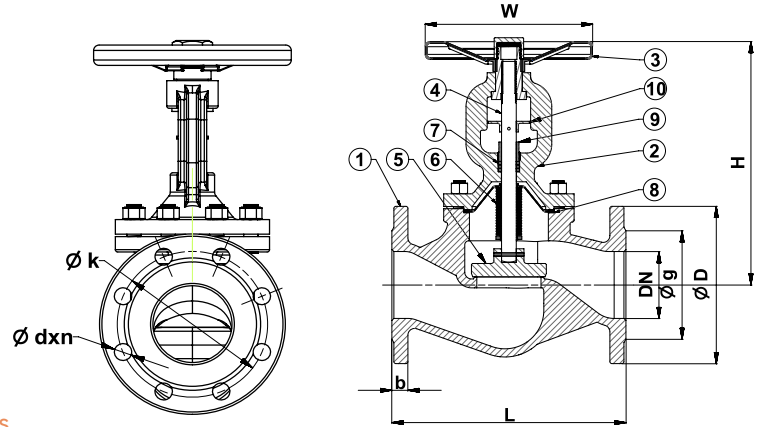

No Parça Adı / Part Name

1 Gövde / Body

2 Kapak / Bonnet

3 Volan / Handwheel

4 Mil / Stem

5 Klape / Disc

6 Körük / Bellow

7 Salmastıra / Packing

8 Conta / Gasket

9 Salmastıra Baskısı / Packing gland

10 Seviye Göstergesi / Level Indicator

Malzeme / Material

GS-C 25 - GP240GH - Çelik Döküm / Steel Iron

GS-C 25 - GP240GH - Çelik Dökü / Steel Iron

St37 - Çelik / Steel

X5CrNi18 10 - AISI304 - Paslanmaz Çelik / Stainless Steel

X5CrNi18 10 - AISI304 - Paslanmaz Çelik / Stainless Steel

X5CrNi18 10 - AISI304 - Paslanmaz Çelik / Stainless Steel

Esnek Grafit Cont / Flexible Graphite Gasket

Esnek Grafit Conta + Paslanmaz Çelik / Flexible Graphite Gasket + Stainless Steel

CuZn40Pb2 - CW617N - Pirinç Dövme / Forced Brass

St37 - Çelik / Steel



Ölçüler Dimensions

Anma Basıncı Nominal Pressure	16 Bar							
Anma Çapı Nominal Diameter	DN	65	80	100	125	150	200	250
Vana Boyutları Valve Dimensions	L	290	310	350	400	480	600	730
	H	255	270	360	380	415	530	665
	W		250	280	300	350	400	450
	D	185	200	220	250	285	340	405
	k	145	160	180	210	240	295	355
	g	122	138	158	188	212	268	320
	b	18	20		22		24	26
dxn	18x4	18x8			22x8		22x12	26x12
Ağırlık Weight	Kg.	20	25	45	60	98	171	340

Sfero Döküm / Ductile Iron

T-1530

Genel Özellikler / General Specifications

Çalışma Sıcaklık Aralığı / Working Temperature : -10 ... +120 °C (16 Bar),
200 °C (13 Bar), 250 °C (11 Bar), 300 °C (10 Bar)

Standartlar / Standards

Sertifikalar / Certificates :

Tasarım / Design : TS EN ISO 4126

Flanş Boyutları / Flange Dimensions : TS EN 1092-2 (PN 16)

Alından Alına Boyutlar / Face to Face Dimensions : TS EN 558 (Seri 8)

Testler / Tests : TS EN 12266-1

Uygulamalar / Applications

Doymuş buhar sistemleri

Saturated steam applications

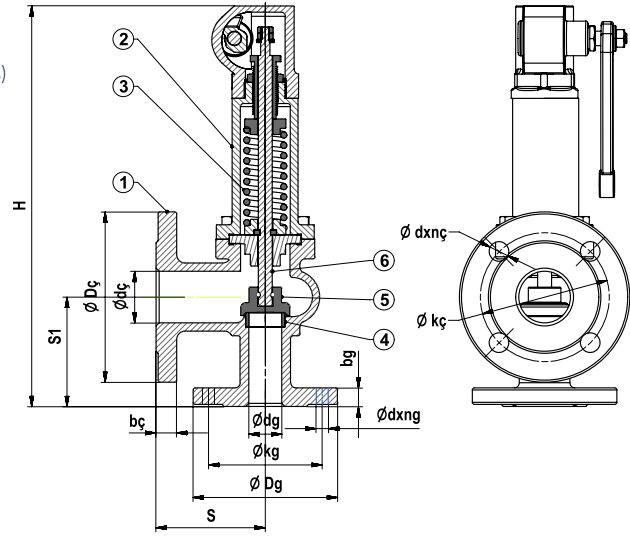

Malzeme Özellikleri Material Specifications

No	Parça Adı / Part Name	Malzeme / Material
1	Gövde / Body	GGG 40 - EN GJS 400-15 - Sfero Döküm / Ductile Iron
2	Kapak / Bonnet	GGG 40 - EN GJS 400-15 - Sfero Döküm / Ductile Iron
3	Yay / Spring	X12CrNi8 8 - AISI302 - Paslanmaz Çelik / Stainless Steel
4	Sit / Seat	X5CrNi8-10 - AISI304 - Paslanmaz Çelik / Stainless Steel
5	Klape / Disc	X5CrNi8-10 - AISI304 - Paslanmaz Çelik / Stainless Steel
6	Mil / Stem	X5CrNi8-10 - AISI304 - Paslanmaz Çelik / Stainless Steel



Ölçüler Dimensions

Anma Basıncı Nominal Pressure	16 Bar								
Anma Çapı Nominal Diameter	DN	25 / 40	32 / 50	40 / 65	50 / 80	65 / 100	80 / 125	100 / 150	
Vana Boyutları Valve Dimensions	S	100	110	115	120	140	160	180	
	S1	105	115	140	150	170	195	220	
	H	410	435	470	490	580	755	860	
	Dg	115	140	150	165	185	200	220	
	Dç	150	165	185	200	220	250	285	
	dg	25	32	40	50	65	80	100	
	dç	40	50	65	80	100	125	150	
	kg	85	100	110	125	145	160	180	
	kç	110	125	145	160	180	210	240	
	bg	16	18		20		22		24
	bç	18	20		22		24		26
Ağırlık Weight	dxng	14x4		19x4		19x8		19x8	
	dxnç	19x4			19x8			23x8	
Ağırlık Weight	Kg	13	16	18	21	33	50	70	

Oransal Kalkışlı Emniyet Ventili (Yaylı, PN 16) Proportional Lift Safety Valve (With Spring, PN 16)



Pik Döküm / Cast Iron

Sfero Döküm / Ductile Iron

T-1510

T-1515



Genel Özellikler / General Specifications

Çalışma Sıcaklık Aralığı / Working Temperature : -10 ... +120 °C (16 Bar),
200 °C (13 Bar), 250 °C (11 Bar), 300 °C (10 Bar)

Standartlar / Standards

Sertifikalar / Certificates :

Tasarım / Design : TS EN ISO 4126

Flanş Boyutları / Flange Dimensions : TS EN 1092-2 (PN 16)

Alından Alına Boyutlar / Face to Face Dimensions : TS EN 558 (Seri 8)

Testler / Tests : TS EN 12266-1

Uygulamalar / Applications

Sıcak ve soğuk su sistemleri, asit ve alkali özelliği bulunmayan sıvı akışkanlar
Hot and cold water systems, non-acidic and non-flammable liquid fluids

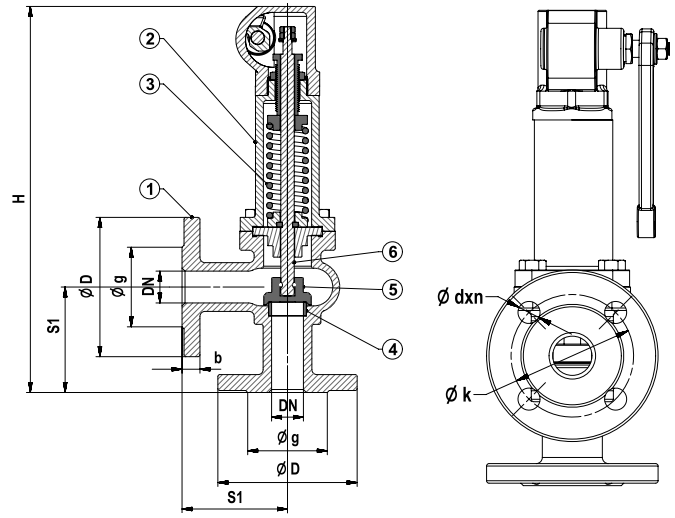

Malzeme Özellikleri Material Specifications

No	Parça Adı / Part Name	Malzeme / Material
1	Gövde / Body	GG 25 - EN GJL 250 - Pik Döküm / Cast Iron (T-1510) GGG 40 - EN GJS 400-15 - Sfero Döküm / Ductile Iron (T-1515)
2	Kapak / Bonnet	GG 25 - EN GJL 250 - Pik Döküm / Cast Iron (T-1510) GGG 40 - EN GJS 400-15 - Sfero Döküm / Ductile Iron (T-1515)
3	Yay / Spring	X12CrNi18 8 - AISI 302 - Paslanmaz Çelik / Stainless Steel
4	Sit / Seat	X5CrNi18 10 - AISI304 - Paslanmaz Çelik / Stainless Steel
5	Klape / Disc	X5CrNi18 10 - AISI304 - Paslanmaz Çelik / Stainless Steel
6	Mil / Stem	X5CrNi18 10 - AISI304 - Paslanmaz Çelik / Stainless Steel



Ölçüler Dimensions

Anma Basıncı Nominal Pressure	16 Bar							
Anma Çapı Nominal Diameter	DN	25	32	40	50	65	80	100
Vana Boyutları Valve Dimensions	S1	100	105	115	125	145	155	175
	H	383	402	413	430	519	584	636
	D	115	140	150	165	185	200	220
	k	85	100	110	125	145	160	180
	g	65	76	84	99	118	132	156
	b	16	18		20		22	24
dxn	14x4	19x4			19x8			
Ağırlık Weight	Kg	9,8	11,7	13,8	17	26,5	30	48

Ters Kovalı Kondenstop (Flanşlı-Dişli, PN 16) Inverted Bucket Steam Trap (Flanged-Threaded, PN 16)



Pik Döküm (Flanşlı) / Cast Iron (Flanged)

Pik Döküm (Dişli) / Cast Iron (Threaded)

T-1610

T-1620



Genel Özellikler / General Specifications

Çalışma Sıcaklık Aralığı / Working Temperature : -10 ... +120 °C (16 Bar),
200 °C (13 Bar), 250 °C (11 Bar), 300 °C (10 Bar)

Standartlar / Standards

Sertifikalar / Certificates :

Tasarım / Design : TS EN ISO 4126

Flanş Boyutları / Flange Dimensions : TS EN 1092-2 (PN 16)

Diş Standardı / Thread Standard : EN ISO 228-1

Testler / Tests : TS EN 12266-1

Uygulamalar / Applications

Doymuş buhar sistemleri

Saturated steam applications



Malzeme Özellikleri Material Specifications

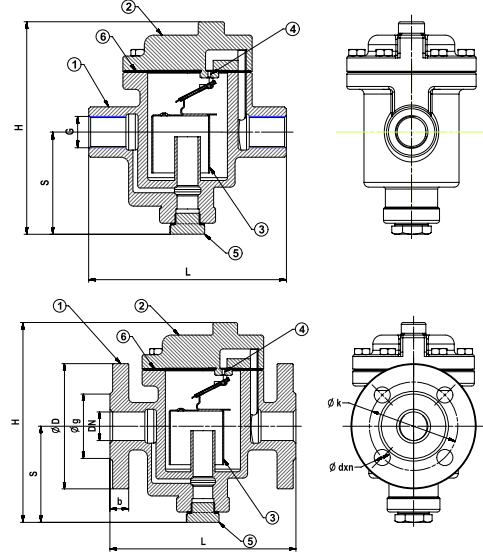

No	Parça Adı / Part Name	Malzeme / Material
1	Gövde / Body	GG 25 - EN GJL 250 - Pik Döküm / Cast Iron (T-1610, T-1620)
2	Kapak / Bonnet	GG 25 - EN GJL 250 - Pik Döküm / Cast Iron (T-1610, T-1620)
3	Kova / Bucket	X5CrNi18 10 - AISI304 - Paslanmaz Çelik / Stainless Steel
4	Orifis / Orifice	X5CrNi18 10 - AISI304 - Paslanmaz Çelik / Stainless Steel
5	Tapa / Plug	St37 - Çelik / Steel
6	Conta / Gasket	Klingerit



Ters Kovalı Kondenstop Flanşlı Ölçüler Inverted Bucket Steam Trap Flanged Dimensions

Anma Basıncı Nominal Pressure	16 Bar						
	DN	15	20	25	32	40	50
Anma Çapı Nominal Diameter							
Vana Boyutları Valve Dimensions	L	170	180	195	205	245	280
	H	170	180	190	200	235	275
	S	90	95	100	105	120	130
	D	95	105	115	140	150	165
	k	65	75	85	100	110	125
	g	46	56	65	76	84	99
	b	14	16		18		20
dxn	14x4			19x4			
Ağırlık Weight	Kg	5,5	6,4	8,1	9,9	15,8	24,9



Ters Kovalı Kondenstop Dişli Ölçüler Inverted Bucket Steam Trap Threaded Dimensions

Anma Basıncı Nominal Pressure	16 Bar						
	DN	15	20	25	32	40	50
Anma Çapı Nominal Diameter							
Vana Boyutları Valve Dimensions	G	1/2"	3/4"	1"	1 1/4"	1 1/2"	2"
	L	140	150	170	180	220	245
	H	170	180	190	200	235	275
	S	90	95	100	105	120	130
Ağırlık Weight	Kg	4,9	6	7,5	7,9	13,4	22,1

Pirinç / Brass

T-0310



Genel Özellikler / General Specifications

Çalışma Sıcaklık Aralığı / Working Temperature : -10 ... +250 °C
Çalışma Basıncı / Working Pressure: 16 Bar'a kadar / Up to 16 Bar

Standartlar / Standards

Sertifikalar / Certificates :
Tasarım / Design : TS 10873
Flanş Boyutları / Flange Dimensions : TS EN 1092-2 (PN 16)
Alından Alına Boyutlar / Face to Face Dimensions : TS EN 558 (Seri 49)
Testler / Tests : TS EN 12266-1

Uygulamalar / Applications

Sıcak ve soğuk su sistemleri, basınçlı hava, asit ve alkali özelliği bulunmayan sıvı akışkanlar, sıvı yakıt sistemleri
Hot and cold water systems, compressed air, non-acidic and non-flammable liquid fluids, liquid fuel systems

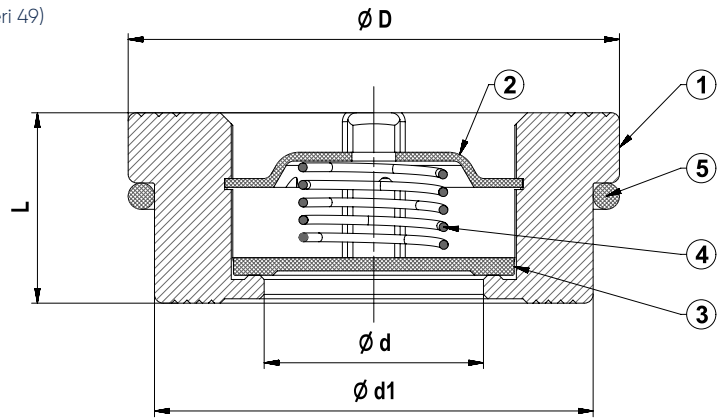

Malzeme Özellikleri Material Specifications

No	Parça Adı / Part Name	Malzeme / Material
1	Gövde / Body	CuZn40Pb2 - CW617N - Pirinç / Brass
2	Klavuz / Disc Guide	X5CrNi18 10 - AISI304 - Paslanmaz Çelik / Stainless Steel
3	Klape / Disc	X5CrNi18 10 - AISI304 - Paslanmaz Çelik / Stainless Steel
4	Yay / Spring	X12CrNi18 8 - AISI302 - Paslanmaz Çelik / Stainless Steel
5	Montaj Yayı / Mounting Spring	X12CrNi18 8 - AISI302 - Paslanmaz Çelik / Stainless Steel



Ölçüler Dimensions

Anma Basıncı Nominal Pressure	16 Bar									
Anma Çapı Nominal Diameter	DN	15	20	25	32	40	50	65	80	100
Vana Boyutları Valve Dimensions	Ød	15	20	25	31.5	39	48	64	74	89
	L	16	19	22	28	31.5	40	46	50	60
	D	40	47	56	72	82	95	115	132	152
	Ød1	36	44	51	67	78	90	108	126	146
Ağırlık Weight	Kg	0.094	0.134	0.202	0.458	0.620	0.976	1.360	2.078	3.030



Min. Açma Basıncı (mBar) Min. Opening Pressure

Disk Tip Çek Vana / Disc Type Check Valve											
Anma Çapı Nominal Diameter		DN	15	20	25	32	40	50	65	80	100
Akış Yönü Flow Direction	Yaylı With Spring	↔	21								
		↓	17	18.3	16.3	16.2	16.1	15	13.7	12.5	
	Yaysız Without Spring	↑	23				24	25		26	26.5
		↓	2.6		3.9	4	4.2	5.1	5.6	7.4	

Sfero Döküm / Ductile Iron

T-0320



Genel Özellikler / General Specifications

Çalışma Sıcaklık Aralığı / Working Temperature : -10 ... +120 °C (16 Bar),
200 °C (13 Bar), 250 °C (11 Bar), 300 °C (10 Bar)

Standartlar / Standards

Sertifikalar / Certificates :

Tasarım / Design : TS EN 16767

Flanş Boyutları / Flange Dimensions : TS EN 1092-2 (PN 16)

Alından Alına Boyutlar / Face to Face Dimensions : TS EN 558 (Seri 49)

Testler / Tests : TS EN 12266-1

Uygulamalar / Applications

Sıcak ve soğuk su sistemleri, basınçlı hava,
asit ve alkali özelliği bulunmayan sıvı akışkanlar, sıvı yakıt sistemleri
Hot and cold water systems, compressed air, non-acidic and
non-flammable liquid fluids, liquid fuel systems



Malzeme Özellikleri Material Specifications

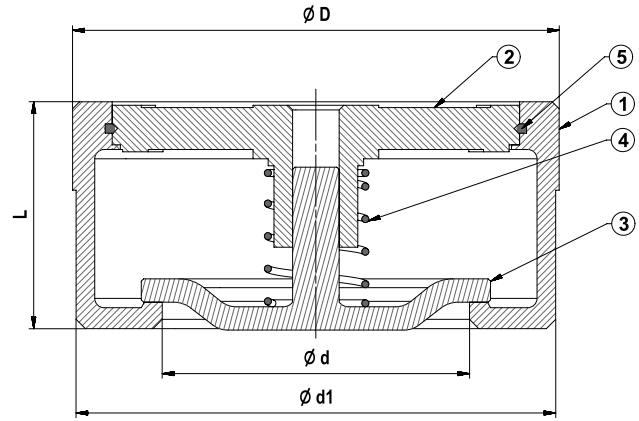

No	Parça Adı / Part Name	Malzeme / Material
1	Gövde / Body	GGG 40 - EN GJS 400-15 - Sfero Döküm / Ductile Iron
2	Klavuz / Disc Guide	GGG 40 - EN GJS 400-15 - Sfero Döküm / Ductile Iron
3	Klape / Disc	GGG 40 - EN GJS 400-15 - Sfero Döküm / Ductile Iron
4	Yay / Spring	X12CrNi18 8 - AISI302 - Paslanmaz Çelik / Stainless Steel
5	Segman / Piston Ring	X12CrNi18 8 - AISI302 - Paslanmaz Çelik / Stainless Steel



Ölçüler Dimensions

Anma Basıncı Nominal Pressure	16 Bar								
Anma Çapı Nominal Diameter	DN	40	50	65	80	100	125	150	200
Vana Boyutları Valve Dimensions	Ød	39	48	64	74	89	112	132	175
	L	31.5	40	46	50	60	90	106	140
	D	82	95	115	132	152	184	209	264
	Ød1	78	90	108	126	146	181	206	260
Ağırlık Weight	Kg	0.620	0.976	1.360	2.078	3.030	6.800	10.000	20.000



Min. Açma Basıncı (mBar) Min. Opening Pressure

Disk Tip Çek Vana										
Anma Çapı Nominal Diameter	DN	40	50	65	80	100	125	150	200	
Akış Yönü Flow Direction	Yaylı With Spring	↔	21				22	23.5	24	
		↓	16.2	16.1	15	13.7	12.5	12	13	14.5
	Yaysız Without Spring	↑	24	25		26	26.5	30	32.5	35
		↓	4	4.2	5.1	5.6	7.4	15	17	18.5

Pik Döküm / Cast Iron

T-0330

Genel Özellikler / General Specifications

Çalışma Sıcaklık Aralığı / Working Temperature : -10 ... +110 °C (16 Bar)
"Pik Kullanım Sıcaklığıdır"

Standartlar / Standards

Sertifikalar / Certificates :

Tasarım / Design : TS EN 16767

Flanş Boyutları / Flange Dimensions : TS EN 1092-2 (PN 16)

Testler / Tests : TS EN 12266-1

Uygulamalar / Applications

Sulama sistemleri, Arıtma sistemleri ve pis su hatları, Yangın tesisatları, Yağ devreleri
Hot and water systems, Irrigation systems and water supply lines, Purification systems and waste water discharge, Fire projection lines, Oil-cooling cycles

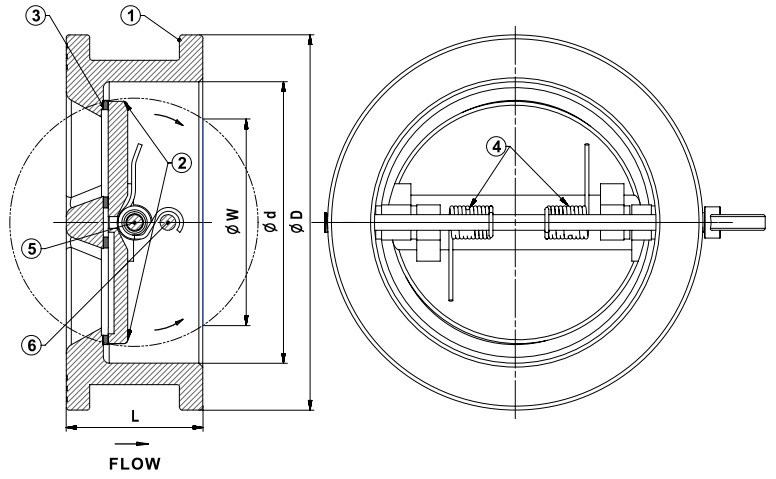

Malzeme Özellikleri Material Specifications

No	Parça Adı / Part Name	Malzeme / Material
1	Gövde / Body	GG 25 - EN GJL 250 - Pik Döküm / Cast Iron
2	Klape / Disc	GGG 40 - EN GJS 400-15 - Sfero Döküm / Ductile Iron
3	Sit / Seat	EPDM - NBR
4	Yay / Spring	X12CrNi18 8 - AISI302 - Paslanmaz Çelik / Stainless Steel
5	Mil / Stem	X20Cr13 - AISI420 - Paslanmaz Çelik / Stainless Steel
6	Stop Pimi / Stop Pin	X20Cr13 - AISI420 - Paslanmaz Çelik / Stainless Steel



Ölçüler Dimensions

Anma Basıncı Nominal Pressure	16 Bar													
Anma Çapı Nominal Diameter	DN	50	65	80	100	125	150	200	250	300	350	400	500	600
Vana Boyutları Valve Dimensions	ØD	107	127	142	162	192	218	273	328	378	438	489	594	695
	Ød	65	80	94	117	145	170	224	265	310	360	410	505	625
	L	43	46	64		70	76	89	114		127	140	152	177
	ØW	49	63	69	97	121	145	197	234	284	333	379	460	527
Ağırlık Weight	Kg	1,3	1,6	2,8	4	5,5	8	13,5	24,4	33	46,4	62	103,4	125

Pik Döküm / Cast Iron

Sfero Döküm/ Ductile Iron

T-0250

T-0260

Genel Özellikler / General Specifications

Çalışma Sıcaklık Aralığı / Working Temperature : -10 ... +120 °C (16 Bar),
200 °C (13 Bar), 250 °C (11 Bar), 300 °C (10 Bar)

Standartlar / Standards

Sertifikalar / Certificates :

Tasarım / Design : TS EN 16767

Flanş Boyutları / Flange Dimensions : TS EN 1092-2 (PN 16)

Alından Alına Boyutlar / Face to Face Dimensions : TS EN 558 (Seri 1)

Testler / Tests : TS EN 12266-1



Uygulamalar / Applications

Sıcak ve soğuk su sistemleri, basınçlı hava,
kızgın su, buhar, kızgın buhar,
asit ve alkali özelliği bulunmayan sıvı akışkanlar
Hot and cold water systems, compressed air,
superheated water, steam,
superheated steam systems,
non-acidic and non-flammable liquid fluids

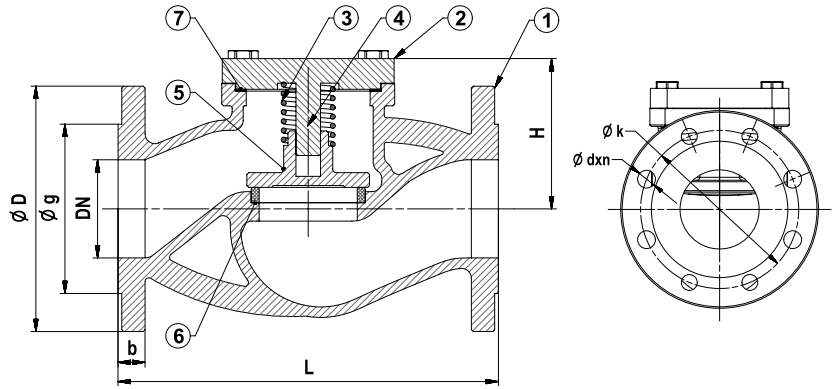

Malzeme Özellikleri Material Specifications

No	Parça Adı / Part Name	Malzeme / Material
1	Gövde / Body	GG 25 - EN GJL 250 - Pik Döküm / Cast Iron (T-0250) GGG 40 - EN GJS 400-15 - Sfero Döküm / Ductile Iron (T-0260)
2	Kapak / Bonnet	GG 25 - EN GJL 250 - Pik Döküm / Cast Iron (T-0250) GGG 40 - EN GJS 400-15 - Sfero Döküm / Ductile Iron (T-0260)
3	Yay / Spring	X12CrNi18 8 - AISI302 - Paslanmaz Çelik / Stainless Steel
4	Mil / Ste	DN 15-100, GG 25 - EN GJL 250 - Pik Döküm / Cast Iron DN 125-300, X20Cr13 - AISI420 - Paslanmaz Çelik / Stainless Steel
5	Klape / Disc	DN 15-80, X20Cr13 - AISI420 - Paslanmaz Çelik / Stainless Steel DN 100-300, St 37 - Çelik + Paslanmaz Çelik / Steel + Stainless Steel
6	Sit / Seat	X5CrNi18 10 - AISI304 - Paslanmaz Çelik / Stainless Steel
7	Conta / Gasket	Grafit / Graphite



Ölçüler Dimensions

Anma Basıncı Nominal Pressure	16 Bar													10 Bar	
	DN	15	20	25	32	40	50	65	80	100	125	150	200	250	300
Vana Boyutları Valve Dimensions	L	130	150	160	180	200	230	290	310	350	400	480	600	730	850
	Min. Strok	5		6	8	10	13	16	20	25	32	40	50	63	75
	H	60	62	65	70	90	95	115	135	145	165	195	238	258	315
	D	95	105	115	140	150	165	185	200	220	250	285	340	405	460
	k	65	75	85	100	110	125	145	160	180	210	240	295	355	410
	g	46	56	65	76	84	99	118	132	156	184	211	266	319	370
	b	14	16		18		20		22	24	26		30	32	
dxn	14x4			19x4				19x8			23x8	23x12	28x12		
Ağırlık Weight	Kg	3	3.5	4.4	5.8	7.9	11.4	15.8	23.5	36	55	71	122	215	325

Pik Döküm / Cast Iron

Sfero Döküm / Ductile Iron

T-0410

T-0420



Genel Özellikler / General Specifications

Çalışma Sıcaklık Aralığı / Working Temperature : -10 ... +120 °C (16 Bar)

Standartlar / Standards

Sertifikalar / Certificates :

Tasarım / Design : TS EN 16767

Flanş Boyutları / Flange Dimensions : TS EN 1092-2 (PN 16)

Alından Alına Boyutlar / Face to Face Dimensions : TS EN 558 (Seri 48)

Testler / Tests : TS EN 12266-1

Uygulamalar / Applications

Sıcak ve soğuk su sistemleri,

asitlik olmayan tüm akışkanlarda

Hot and cold water, all non acidic fluids

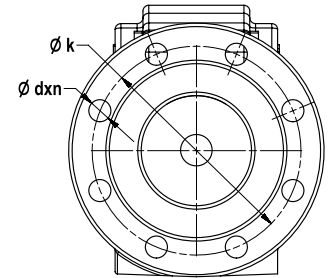
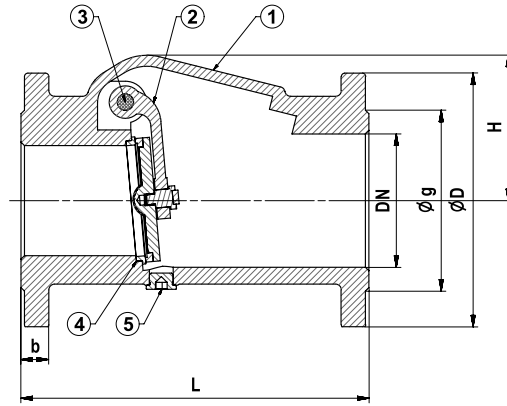

Malzeme Özellikleri Material Specifications

No	Parça Adı / Part Name	Malzeme / Material
1	Gövde / Body	GG 25 - EN GJL 250 - Pik Döküm / Cast Iron (T-0410) DN 40-150 GGG 40 - EN GJS 400-15 - Sfero Döküm / Ductile Iron (T-0420)
2	Klape / Disc	GGG 40 - EN GJS 400-15 - Sfero Döküm + Kauçuk Kaplama / Ductile Iron + Rubber Coated
3	Mil / Stem	X20Cr13 - AISI420 - Paslanmaz Çelik / Stainless Steel
4	Sitler / Seats	CuZn40Pb2 - CW617N - Piriç - Paslanmaz Çelik - Bronz / Brass - Stainless Steel - Bronze
5	Tapa / Plug	St37 - Çelik / Steel



Ölçüler Dimensions

Anma Basıncı Nominal Pressure	16 Bar											
Anma Çapı Nominal Diameter	DN	40	50	65	80	100	125	150	200	250	300	350
Vana Boyutları Valve Dimensions	L	180	200	240	260	300	350	400	500	600	700	800
	H	70		87	104	125	157	186	240	295	372	375
	D	150	165	185	200	220	250	285	340	405	460	520
	k	110	125	145	160	180	210	240	295	355	410	470
	g	84	99	118	132	156	184	211	266	319	370	420
	b	18	20		22	24	26		20	22	25	36
	dxn	19x4			19x8			23x8	23x12	28x12		28x16
Ağırlık Weight	Kg	6	7,5	10,5	14	20	30	43	70	120	164	215

* Sit sadece DN 300 ve DN 350 anma çaplarında mevcuttur.

* The seat is only for diameters DN 300 & DN 350

Karbon Çelik Döküm / Cast Carbon Steel

T-0430

Genel Özellikler / General Specifications

Çalışma Sıcaklık Aralığı / Working Temperature : -10 ... +110 °C (16 Bar)
"Pik Kullanım Sıcaklığıdır"

Standartlar / Standards

Sertifikalar / Certificates :

Flanş Boyutları / Flange Dimensions : TS EN 1092-2 (PN 16)

Testler / Tests : TS EN 12266-1

Uygulamalar / Applications

Deniz suyu (paslanmaz çelik), kondens sistemleri
(paslanmaz çelik), arıtma sistemleri, HVAC sistemleri
Sea water (stainless steel), condensation systems
(stainless steel), purification systems, HVAC systems

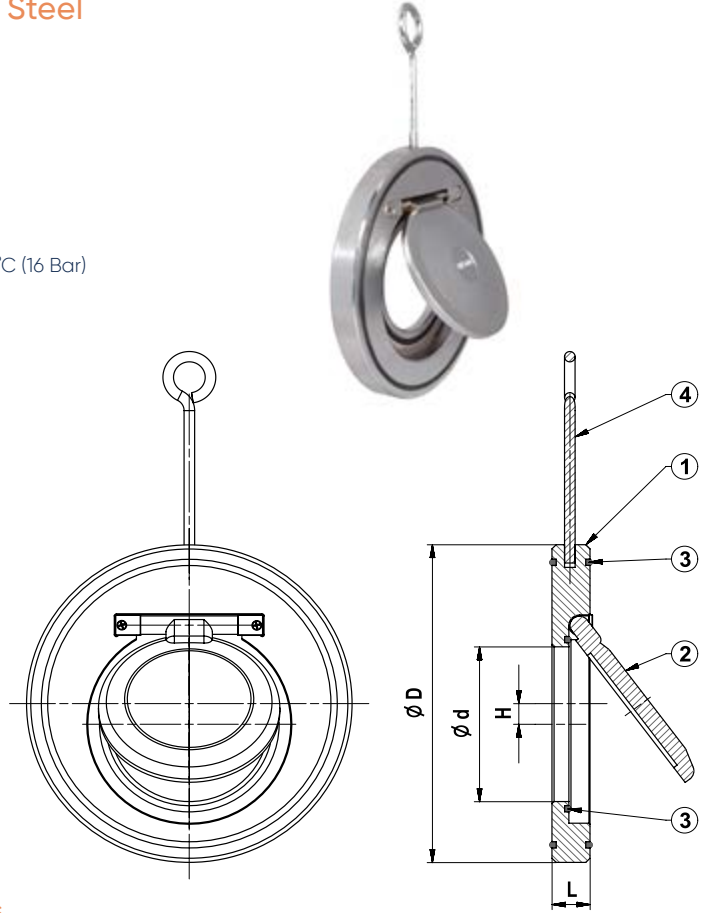

Malzeme Özellikleri Material Specifications

No	Parça Adı / Part Name	Malzeme / Material
1	Gövde / Body	GS-C 25 - GP240GH Karbon Çelik Döküm + Nikel Kaplama / Cast Carbon Steel + Nickel Plated (T-0430) - Cast Stainless Steel (T-0450)
2	Klape / Disc	GS-C 25 - GP240GH Karbon Çelik Döküm + Nikel Kaplama / Cast Carbon Steel + Nickel Plated (T-0430) - Cast Stainless Steel (T-0450)
3	O-Ring / O-Ring	EPDM - NBR
4	Mapa / Eye Bolt	St 37 - Çelik + Nikel Kaplama / Steel + Nickel Plated



Ölçüler Dimensions

Anma Basıncı Nominal Pressure	16 Bar														
Anma Çapı Nominal Diameter	DN	40	50	65	80	100	125	150	200	250	300	350	400	500	600
Vana Boyutları Valve Dimensions	ØD	92	107	127	142	162	192	218	273	329	384	444	491	610	724
	Ød	22	32	40	54	70	92	114	154	200	235	280	316	405	486
	L	14			18			20	22	26	28	38	44	56	62
	H	0		2	3	4	5	6	8	9	10	11	12	13	15
Ağırlık Weight	Kg	0,7	0,8	1,2	1,5	2,3	3,5	4,1	7	12	18	22	25	30	40

Sfero Döküm / Ductile Iron

CVT-1010

Genel Özellikler / General Specifications

Çalışma Sıcaklık Aralığı / Working Temperature : -10 ... +110 °C (16 Bar)

Standartlar / Standards

Sertifikalar / Certificates :

Bağlantı Boyutları / Connection Dimensions : TS EN 1092-2 (PN 16)

Testler / Tests : TS EN 12266-1

Uygulamalar / Applications

Sıcak ve soğuk su sistemleri, basınçlı hava, asit ve alkali özelliği bulunmayan sıvı akışkanlar
Hot and cold water systems, compressed air, non-acidic and non-flammable liquid fluids

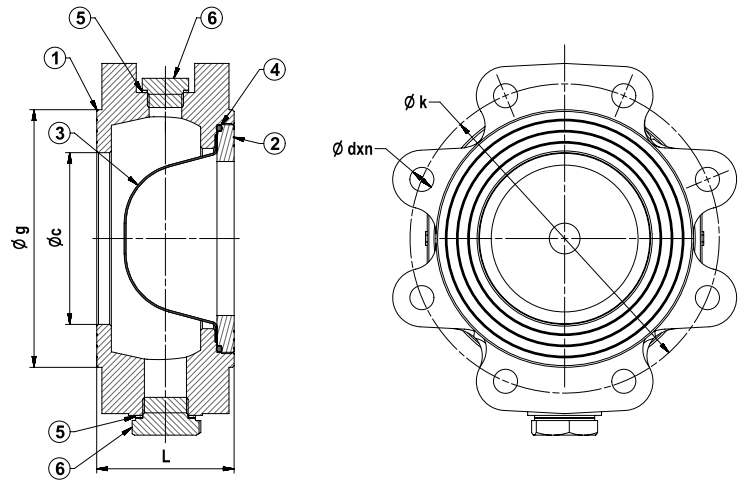

Malzeme Özellikleri Material Specifications

No	Parça Adı / Part Name	Malzeme / Material
1	Gövde / Body	GGG 40 - EN GJS 400-15 - Sfero Döküm / Ductile Iron
2	Kapak / Bonnet	GGG 40 - EN GJS 400-15 - Sfero Döküm / Ductile Iron
3	Filtre / Filter	AISI304 L - Paslanmaz Çelik / Stainless Steel
4	O-Ring	EPDM
5	Tapa Contası / Plug Gasket	Bakır / Copper
6	Tapa / Plug	St37 - Çelik / Steel



Ölçüler Dimensions

Anma Basıncı Nominal Pressure	16 Bar												
Anma Çapı Nominal Diameter	DN	40	50	65	80	100	125	150	200	250	300	350	400
Vana Boyutları Valve Dimensions	L	50		65		80	100	125	150	200	250	300	350
	D	84	99	118	132	150	184	208	266	319	370	429	481
	c	40	50	65	80	100	125	150	200	250	300	350	400
	k	110	125	145	160	180	210	240	295	355	410	470	525
	dxn	M16x4			M16x8			M20x8	M20x12	M24x12		M24x16	M27x16
Ağırlık Weight	Kg	2.5	3	3,8	5.2	6.6	9.8	14.7	23,5	38,6	56,6	82,2	106,4
Filtre Filter	Kalınlık (mm) / Thickness (mm)	1					1,5			2			

Y Tipi Pislik Tutucu (PN 16) Y Type Strainer (PN 16)



Pik Döküm / Cast Iron

Sfero Döküm / Ductile Iron

T-0820

T-0830

Genel Özellikler / General Specifications

Çalışma Sıcaklık Aralığı / Working Temperature : -10 ... +120 °C (16 Bar),
200 °C (13 Bar), 250 °C (11 Bar), 300 °C (10 Bar)

Standartlar / Standards

Sertifikalar / Certificates :

Tasarım / Design : TS 11494

Flanş Boyutları / Flange Dimensions : TS EN 1092-2 (PN 16)

Alından Alına Boyutlar / Face to Face Dimensions : TS EN 558 (Seri 1)

Testler / Tests : TS EN 12266-1

Uygulamalar / Applications

Sıcak ve soğuk su sistemleri, basınçlı hava, doymuş buhar,
asit ve alkali özelliği bulunmayan sıvı akışkanlar
Hot and cold water systems, compressed air, saturated steam,
non-acidic and non-flammable liquid fluids

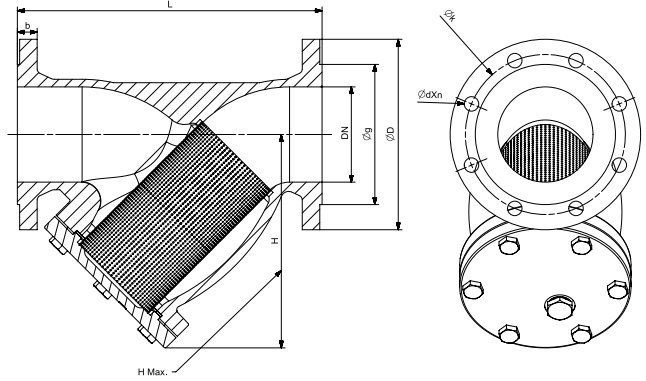

Malzeme Özellikleri Material Specifications

No Parça Adı / Part Name

1 Gövde / Body

2 Kapak / Bonet

3 Filtre / Filter

4 Takviye Sacı / Reinforcing Frame (DN 50-800)

5 Conta / Gasket

6 Tapa Contası / Plug Gasket (DN 50-800)

7 Tapa / Plug (DN 50-800)

Malzeme / Material

GG 25 - EN G.JL 250 - Pik Döküm / Cast Iron (T-0820) DN 15-300

GGG 40 - EN G.JS 400-15 - Sfero Döküm / Ductile Iron (T-0830)

GG 25 - EN G.JL 250 - Pik Döküm / Cast Iron (T-0820) DN 15-300

GGG 40 - EN G.JS 400-15 - Sfero Döküm / Ductile Iron (T-0830)

X5CrNi8 10 - AISI304 - Paslanmaz Çelik / Stainless Steel

Paslanmaz Çelik / Stainless Steel

Grafit / Graphite

Bakır / Copper

St37



Ölçüler Dimensions

Anma Basıncı Nominal Pressure	16 Bar																											
Anma Çapı Nominal Diameter	DN	15	20	25	32	40	50	65	80	100	125	150	200*	250*	300*	350	400	500	600	700	800							
Vana Boyutları Valve Dimensions	L	130	150	160	180	200	230	290	310	350	400	480	600	730	850	980	1100	1250	1450	1650	1850							
	H	65	78	88	126	135	145	165	175	236	267	298	340	390	440	520	630	900	1100	1300	1750							
	H max.	117	140	160	203	232	260	333	363	454	510	579	657	875	960	1160	1329	1750	2000	2350	2950							
	D	95	105	115	140	150	165	185	200	220	250	285	340	405	460	520	580	715	840	910	1025							
	k	65	75	85	100	110	125	145	160	180	210	240	295	355	410	470	525	650	770	840	950							
	g	46	56	65	76	84	99	118	132	156	184	211	266	319	370	429	480	609	720	794	901							
	b	14	16			18		20		22	24	26	22	25	25	26,5	28	31,5	36	39,5	43							
dxn		14x4			19x4			19x8			23x8		23x12		28x12		28x16		31x16		34x20		37x20		37x24		41x24	
Ağırlık Weight	Kg	2	3	4	6,5	7,5	10,5	16	21,5	28,5	39	52,5	69	114,5	180	350	429	610	735	870	980							

*Sfero Döküm / Ductile Iron



Filtre Filter

Sac Kalınlığı Sheet Thickness	0,8 mm						0,5 mm		0,8 mm		1,0 mm		1,5 mm		2,0 mm		
Anma Çapı Nominal Diameter	DN	15	20	25	32	40	50	65	80	100	125	150	200	250	300	350	400
Delik Çapı (R) Hole Diameter	Ød	23±0,5	28±0,5	36±0,5	42±0,5	46±0,5	55±0,5	78±0,5	85±0,5	109±1	135±1	160±1	210±1	258±1	308±1	365±1	410±1
	L	56±0,5	68±0,5	82±0,5	98±0,5	96±0,5	98±0,5	132±0,5	149±0,5	192-1,5	227-1,5	244-1,5	313-1,5	394-1,5	434-2	630-2	645-2
	Açıklığı	75±0,5	90±0,5	105±0,5	145±0,5	150±1	180±2	251±2	287±2	348±2	430±2	506±2	666±3	832±3	983±3	1162±3	1303±3
Delik Aralığı (T) Hole Interval	30 MESH □0,6						2 mm		2 mm		4 mm		5 mm		6 mm		
							4 mm		4 mm		6 mm		8 mm		10 mm		

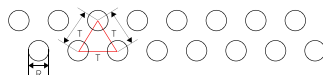

Plakada delik konumu

Pik Döküm / Cast Iron

Sfero Döküm/ Ductile Iron

T-0821 T-0831

Genel Özellikler / General Specifications

Çalışma Sıcaklık Aralığı / Working Temperature : -10 ... +120 °C (16 Bar),
200 °C (13 Bar), 250 °C (11 Bar), 300 °C (10 Bar)

Standartlar / Standards

Sertifikalar / Certificates :

Tasarım / Design : TS 11494

Flanş Boyutları / Flange Dimensions : TS EN 1092-2 (PN 16)

Alından Alına Boyutlar / Face to Face Dimensions : TS EN 558 (Seri 1)

Testler / Tests : TS EN 12266-1

Uygulamalar / Applications

Sıcak ve soğuk su sistemleri, basınçlı hava, doymuş buhar, asit ve alkali özelliği bulunmayan sıvı akışkanlar üzerinde bulunan manometreler sayesinde zaman içerisinde filtrede meydana gelen tıkanıklıklar takip edilebilir. Basınç kayıpları izlenebilir. Hot and cold water systems, compressed air, saturated steam, non-acidic and non-flammable liquid fluids thanks to the manometers on it, the clogging that occur in the filter can be followed over time. Pressure losses can be followed.

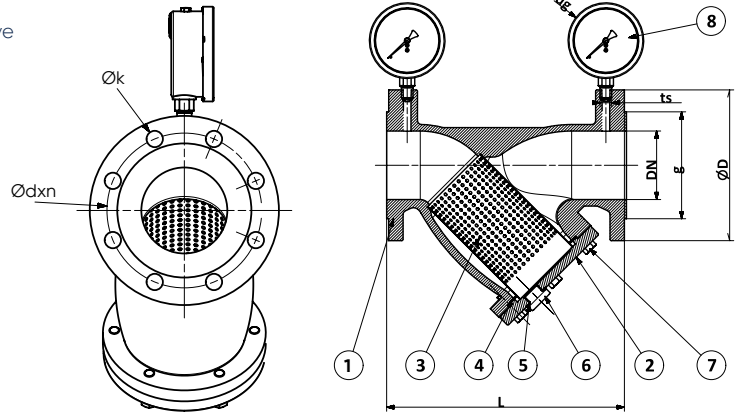

Malzeme Özellikleri Material Specifications

No	Parça Adı / Part Name	Malzeme / Material
1	GÖVDE / Body	*GG 25 - EN GJL 250 - PİK DÖKÜM / Cast Iron (T-0820) DN15...300 GGG 40 - EN GJS 400-15 - SFERO DÖKÜM / Ductile Iron (T-0830) *
2	KAPAK / Bonnet	*GG 25 - EN GJL 250 - PİK DÖKÜM / Cast Iron (T-0820) DN15...300 GGG 40 - EN GJS 400-15 - SFERO DÖKÜM / Ductile Iron (T-0830) *
3	FİLTRE/Filter	AISI 304
4	CONTA/Gasket	KLİNGERİT/Klingerit
5	TAPA CONTASI /Plug Gasket (DN50..800)	BAKIR/Copper
6	TAPA/Plug (DN50..800)	St37
7	Çıvata /Bolts	Çelik/Steel
8	Manometre/Pressure Gauge	



Ölçüler Dimensions

Anma Basıncı Nominal Pressure	16 Bar													
Anma Çapı Nominal Diameter	DN	50	65	80	100	125	150	200*	250*	300*	350	400	500	
Vana Boyutları Valve Dimensions	L	230	290	310	350	400	480	600	730	850	980	1100	1250	
	H	145	165	175	236	267	298	340	390	440	520	630	900	
	H max.	260	333	363	454	510	579	657	875	960	1160	1329	1750	
	D	165	185	200	220	250	285	340	405	460	520	580	715	
	dg	Ø100												
	ts	3/8" NPT						1/2" NPT						
	k	125	145	160	180	210	240	295	355	410	470	525	650	
	g	99	118	132	156	184	211	266	319	370	429	480	609	
	b	20			22	24	26		22	25	26,5	28	31,5	
	dxn					19x8		23x8	23x12	28x12		28x16	31x16	34x20
Ağırlık Weight	kg	10,5	16	21,5	28,5	39	52,5	69	114,5	180	350	429	623	

*Sfero Döküm / Ductile Iron

Filtre Filter

Sac Kalınlığı Sheet Thickness		0.5 mm	0.8 mm	1 mm	1.5 mm	2 mm	3						
Anma Çapı Nominal Diameter	DN	50	65	80	100	125	150	200	250	300	350	400	500
Delik Çapı (R) Hole Diameter		2			4	5	6		6		6		
Delik Aralığı (T) Hole Interval		4			6	8	10		10			10	

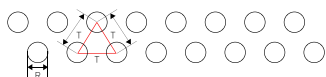

DUYAR 
Since 1965

55 YILDIR
5 KITADA 75 ÜLKEDE

Kauçuk Kaplı
Wafer Kelebek Vana



Lug Vulkanize
Kelebek Vana



Elastomer Sıtlı
Sürgülü Vana



Lug
Pislik tutucu



    /DuyarVana | Duyar.com



Çelik boru / Steel Pipe

T-1755

Çelik boru / Steel Pipe

T-1765

Çelik boru / Steel Pipe

T-1775

Çelik boru / Steel Pipe

T-1785

Genel Özellikler / General Specifications

Çalışma Sıcaklık Aralığı / Working Temperature : -10... +120 °C (16 Bar)

Standartlar / Standards

Sertifikalar / Certificates :

Tasarım / Design : TS EN 14384

Bağlantı Boyutları / Connection Dimensions : TS EN 1092-2 (PN 16)

Testler / Tests : TS EN 12266-1

Uygulamalar / Applications

Yangın tesisatları

Fire installations



Malzeme Özellikleri Material Specifications

No	Parça Adı / Part Name	Malzeme / Material
1	Gövde / Body	GG 25 - EN GJL 250 - Pik Döküm / Cast Iron
2	Alt Boru / Lower Pipe	St 37 - Çelik çekme / Steel Extrusion
3	Çatal / Fork	GG 25 - EN GJL 250 - Pik Döküm / Cast Iron
4	Kaplin / Coupling	Alüminyum Alaşımli / Alüminum Alloy
5	Volan / Handwheel	GG 25 - EN GJL 250 - Pik Döküm / Cast Iron
6	Klape / Seat Seal	GGG 40 - EN GJS 400-15 - Sféro Döküm + Kauçuk Kaplama / Ductile Iron+rubber plated
7	Çekvalf / Check Valve	CuZn40Pb2- CW617N Piring / Brass
8	Alt Flanş / Lower Flange	GG 25 - EN GJL 250 - Pik Döküm / Cast Iron
9	Üst Flanş / Upper Flange	GG 25 - EN GJL 250 - Pik Döküm / Cast Iron

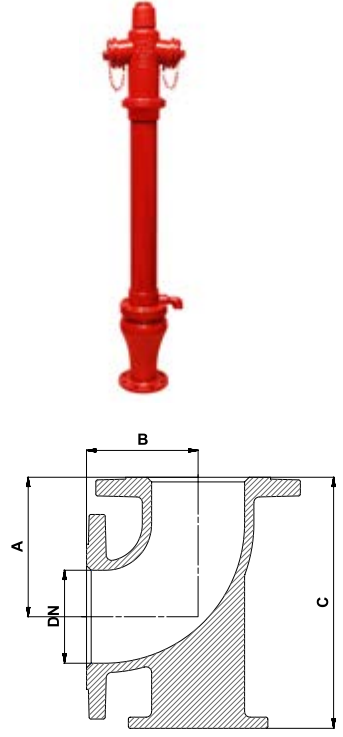
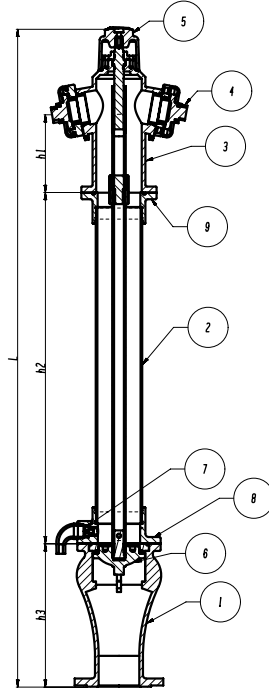

Ürün Kodu / Product code	h1	h2	h3	L
T-1755	190	430	350	1180
T-1765		1000		1750
T-1775		1290		2040
T-1785		1720		2470



Ölçüler Dimensions

Anma Basıncı / Nominal Pressure	16 Bart
DN	100
L	T-1755 : 1180
	T-1765 : 1750
	T-1775 : 2040
	T-1785 : 2470
Çıkış Ölçüsü / Outlet Dimension	2x65
Tip / Type	C
Akış Kesme Sistemi / Flow Cut Systems	Kuru Tip / Dry Type
KV Debi Kapasitesi / Flowrate (m ³ / h)	210



Dirsek

A	150
B	120
C	270

Pik Döküm / Cast Iron

T-1720

Genel Özellikler / General Specifications

Çalışma Sıcaklık Aralığı / Working Temperature : -10... +120 °C (16 Bar)

Standartlar / Standards

Sertifikalar / Certificates :

Tasarım / Design : TS EN 14384

Bağlantı Boyutları / Connection Dimensions : TS EN 1092-2 (PN 16)

Testler / Tests : TS EN 12266-1

Uygulamalar / Applications

Yangın tesisatları

Fire installations

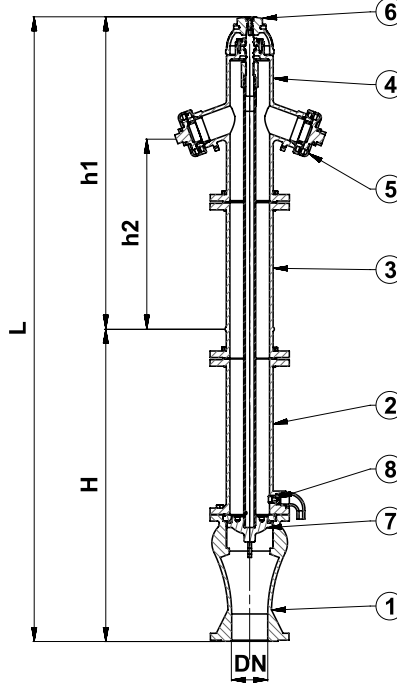

Malzeme Özellikleri Material Specifications

No	Parça Adı / Part Name	Malzeme / Material
1	Gövde / Body	GG 25 - EN GJL 250 - Pik Döküm / Cast Iron
2	Alt Boru / Lower Pipe	GG 25 - EN GJL 250 - Pik Döküm / Cast Iron
3	Üst Boru / Upper Pipe	GG 25 - EN GJL 250 - Pik Döküm / Cast Iron
4	Çatal / Fork	GG 25 - EN GJL 250 - Pik Döküm / Cast Iron
5	Kaplin / Coupling	Alüminyum Alaşım / Aluminum Alloy
6	Volan / Handwheel	GG 25 - EN GJL 250 - Pik Döküm / Cast Iron
7	Klape / Seat Seal	GGG 40 - EN GJS 400-15 - Sfero Döküm + Kauçuk Kaplama / Ductile Iron + Rubber Coated
8	Çekvalf / Check Valve	CuZn40Pb2 - CW617N - Pirinç / Brass



Ölçüler Dimensions

Anma Basıncı / Nominal Pressure	16 Bar
DN	80
H	850
h1	900
h2	540
L	1750
Çıkış Ölçüsü / Outlet Dimension	2 x 2"
Tip / Type	C
Akış Kesme Sistemi / Flow Cut Systems	Kuru Tip / Dry Type
KV Debi Kapasitesi / Flowrate (m ³ /h)	106

Pik Döküm / Cast Iron

T-1750

Dirsek / Flange Bend

T-1760

Kazan / Surface Box

T-1770

Genel Özellikler / General Specifications

Çalışma Sıcaklık Aralığı / Working Temperature : -10... +120 °C (16 Bar)

Standartlar / Standards

Sertifikalar / Certificates :

Tasarım / Design : TS EN 14339

Bağlantı Boyutları / Connection Dimensions : TS EN 1092-2 (PN 16)

Testler / Tests : TS EN 12266-1

Uygulamalar / Applications

Yangın tesisatları, sulama sistemleri
Fire installations, irrigation systems

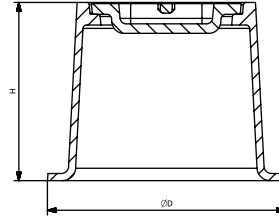

T-1770

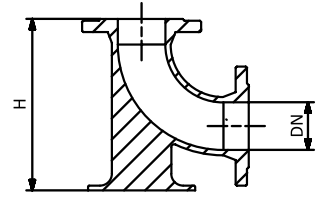
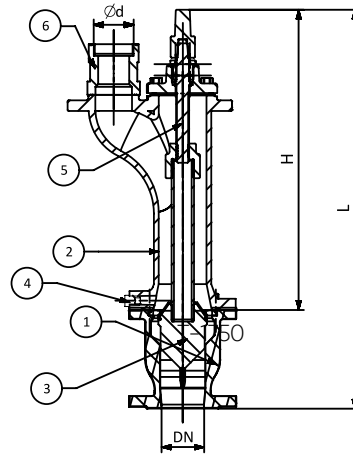

T-1760



Malzeme Özellikleri Material Specifications

No	Parça Adı / Part Name	Malzeme / Material
1	Gövde / Body	GG 25 - EN GJL 250 - Pik Döküm / Cast Iron
2	Üst Gövde / Upper Body	GG 25 - EN GJL 250 - Pik Döküm / Cast Iron
3	Klape / Seat Seal	GGG 40 - EN GJS 400-15 - Sfero Döküm + Kauçuk Kaplama / Ductile Iron + Rubber Coated
4	Çekvalf / Check Valve	CuZn40Pb2 - CW617N - Piriç / Brass
5	Mil / Stem	X20Cr13 - AISI420 - Paslanmaz Çelik / Stainless Steel
6	Kaplin / Coupling	GG 25 - EN GJL 250 - Pik Döküm / Cast Iron



Ölçüler Dimensions

T-1750	
Anma Basıncı / Nominal Pressure	16 Bar
DN	80
H	560
L	750
Çıkış Ölçüsü / Outlet Dimension	1 x 2 1/2"
Tip / Type	C
Akış Kesme Sistemi / Flow Cut Systems	Kuru Tip / Dry Type
KV Debi Kapasitesi / Flowrate (m ³ / h)	106

T-1760	
Anma Basıncı Nominal Pressure	16 Bar
DN	80
H	290

T-1770	
Anma Basıncı Nominal Pressure	16 Bar
Ø D	360
H	270

Kauçuk Kompansatör (Flanşlı, PN 16) Rubber Expansion Joint (Flanged, PN 16)



Sfero Döküm Flaşlı DN 25-300
/ Ductile Iron Flange

Çelik Flaşlı DN 350-600
/ Steel Flange

T-1810

T-1810



Genel Özellikler / General Specifications

Çalışma Sıcaklık Aralığı / Working Temperature :
-20... +90 °C 40 °C (16 Bar), 60 °C (10 Bar), 90 °C (6 Bar)

Standartlar / Standards

Sertifikalar / Certificates :
Tasarım / Design : TS 10879
Bağlantı Boyutları / Connection Dimensions :
TS EN 1092-2 (PN 16) Testler / Tests : TS EN 12266-1
Testler / Tests : TS EN 12266-1

Uygulamalar / Applications

Sıcak ve soğuk su sistemleri, asit ve alkali özelliği bulunmayan sıvı akışkanlar, sıvı yakıt tesisatları
Hot and cold water systems, non-acidic and non-flammable liquid fluids, liquid fuel systems

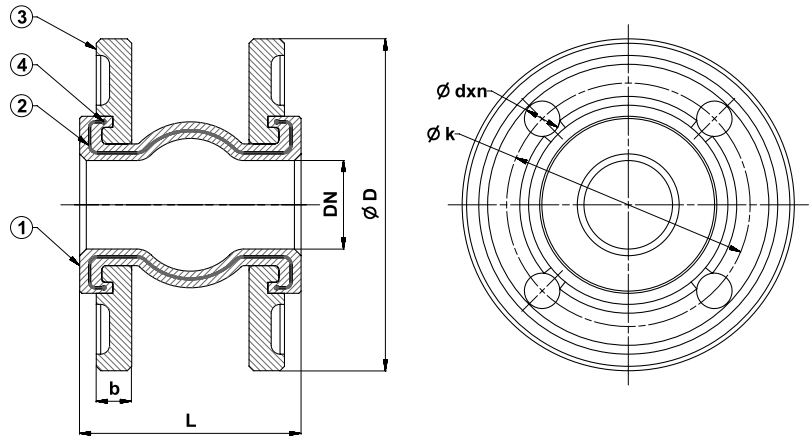

Malzeme Özellikleri Material Specifications

No	Parça Adı / Part Name	Malzeme / Material
1	Gövde / Body	Kauçuk / Rubber
2	Kort Bezi / Kord Fabric	Sentetik Fiber / Nylon 66
3	Flanş / Flange	DN 25-300, GGG 40 - EN GJS 400-15 - Sfero Döküm + Galvaniz Kaplama / Ductile Iron + Galvanize Plated DN 350-600, St 37 - Çelik + Galvaniz Kaplama / Steel + Galvanize Plated
4	Segman / Piston Ring	Karbon Çelik / Carbon Steel



Ölçüler Dimensions

Anma Basıncı Nominal Pressure	16 Bar																			
Anma Çapı Nominal Diameter	DN	25	32	40	50	65	80	100	125	150	200	250	300	350	400	450	500	600		
Boyutlar Dimensions (mm)	L	100							120			115	130	160	240	250	270	260		
	ØD	115	150	165	185	200	220	250	285	340	405	460	520	565	615	670	780			
	Eksenel Genleşme / Axial Expansion	+ 10mm																		
	Eksenel Kapanma / Axial Compression	- 20mm																		
	Yanal Hareket / Lateral Movement	15mm																		
	Açısal Hareket / Angular Movement	10°																		
	k	85	100	110	125	145	160	180	210	240	295	355	410	470	515	565	620	725		
	b	16			18			20			22		24	26	28	30	26	28		
dxn	14x4		19x4				19x8			23x8		23x12		26x12		26x16		26x20		30x20
Ağırlık Weight	Kg	1,8	3,3	3,8	4,5	5,2	6,7	7,8	9,6	11,8	16,8	20	28	42,4	46	51	57	70		

Pik Döküm / Cast Iron

T-1815

Genel Özellikler / General Specifications

Çalışma Sıcaklık Aralığı / Working Temperature :
-20... +115 °C 40 °C (16 Bar), 60 °C (10 Bar), 90 °C (6 Bar)

Standartlar / Standards

Sertifikalar / Certificates :
Tasarım / Design : TS 10879
Diş Standardı / Thread Standard : ISO 7 - 1 DIN 2999,BSPT
Testler / Tests : TS EN 12266-1

Uygulamalar / Applications

Sıcak ve soğuk su sistemleri, asit ve alkali özelliği bulunmayan sıvı akışkanlar, sıvı yakıt tesisatları
Hot and cold water systems, non-acidic and non-flammable liquid fluids, liquid fuel systems

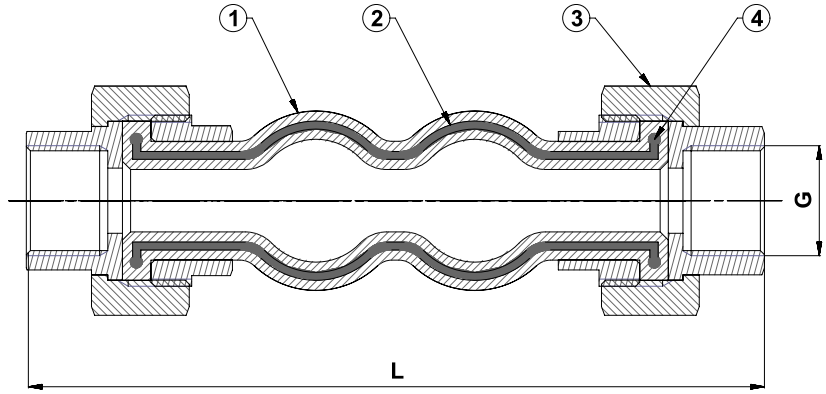

Malzeme Özellikleri Material Specifications

No	Parça Adı / Part Name	Malzeme / Material
1	Gövde / Body	Kauçuk / Rubber
2	Kord Bezi / Kord Fabric	Sentetik Fiber / Nylon 6.6
3	Rakor / Rotary Joint	Dövülebilir Dökme Demir / Forgeable Cast Iron
4	Segman / Piston Ring	Karbon Çelik / Carbon Steel



Ölçüler Dimensions

Anma Basıncı Nominal Pressure	16 Bar									
Anma Çapı Nominal Diameter	DN	15	20	25	32	40	50	65	80	
Boyutlar Dimensions (mm)	G	1 / 2"	3 / 4"	1"	1 1 / 4"	1 1 / 2"	2"	2 1 / 2"	3"	
	L	180			200	210	220	245	285	
	Eksenel Genleşme Axial Expansion	+ 6mm								
	Eksenel Kapanma Axial Compression	-16mm								
	Yanal Hareket Lateral Movement	15mm								
Açısal Hareket Angular Movement	10°									
Ağırlık Weight	Kg	0,5	0,75	1	1,4	2	2,6	4	5,6	

Movement 30mm
(-20 ... +10 mm) DN 25-250

T-1840 Movement 60mm
(-40 ... +20 mm) DN 50-250

T-1820

T-1840



Genel Özellikler / General Specifications
Çalışma Sıcaklık Aralığı / Working Temperature :
-80 ... +420°C (16 Bar)

Standartlar / Standards

Sertifikalar / Certificates :

Tasarım / Design : TS 10880

Bağlantı Boyutları / Connection Dimensions : TS EN 1092-1 (PN 16)

Testler / Tests : TS EN 12266-1

Uygulamalar / Applications

Sıcak ve soğuk su sistemleri, basınçlı hava, kızgın su, buhar, kızgın buhar, kızgın yağ sistemleri
Hot and cold water systems, compressed air, superheated water, steam, superheated steam systems, superheated oil systems

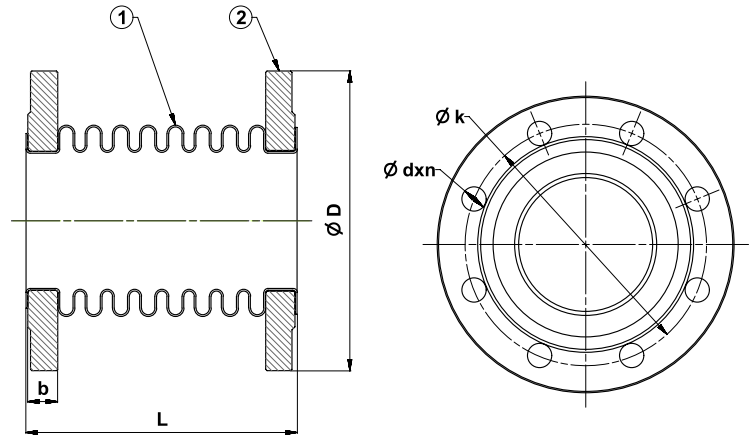

Malzeme Özellikleri Material Specifications

No	Parça Adı / Part Name	Malzeme / Material
1	Körük / Bellow	X5CrNi18 10 - AISI304 - Paslanmaz Çelik / Stainless Steel
2	Flanş / Flange	St37 - Çelik / Steel



Ölçüler Dimensions

Anma Basıncı Nominal Pressure	16 Bar												
Anma Çapı Nominal Diameter	DN	25	32	40	50	65	80	100	125	150	200	250	300
T-1820	L 30mm (-20 ... +10mm)	110	110	120	120	120	120	120	125	130	150	165	165
T-1840	L 60mm (-40 ... +20mm)	-	-	-	180	180	180	185	190	200	230	245	245
T-1820	Eksenel Hareket Axial Movement	30mm (-20 ... +10mm)											
T-1840		60mm (-40 ... +20mm)											
Boyutlar Dimensions (mm)	ØD	115	140	150	165	185	200	220	250	285	340	405	460
	k	85	100	110	125	145	160	180	210	240	295	355	410
	b	16	18	18	20	20	20	22	22	24	26	29	32
	dxn	14x4	18x4	18x4	18x4	18x4	18x8	18x8	18x8	22x8	22x12	26x12	26x12

Movement 30mm
(-20 ... +10 mm) DN 25 - 250

Movement 60mm
(-40 ... +20 mm) DN 50 - 250

T-1830

T-1850



Genel Özellikler / General Specifications

Çalışma Sıcaklık Aralığı / Working Temperature :
-80 ... +420°C (16 Bar)

Standartlar / Standards

Sertifikalar / Certificates :
Tasarım / Design : TS 10880
Bağlantı Boyutları / Connection Dimensions : TS EN 1092-1 (PN 16)
Testler / Tests : TS EN 12266-1

Uygulamalar / Applications

Sıcak ve soğuk su sistemleri, basınçlı hava,
kızgın su, buhar, kızgın buhar, kızgın yağ sistemleri
Hot and cold water systems, compressed air, superheated water,
steam, superheated steam systems, superheated oil systems

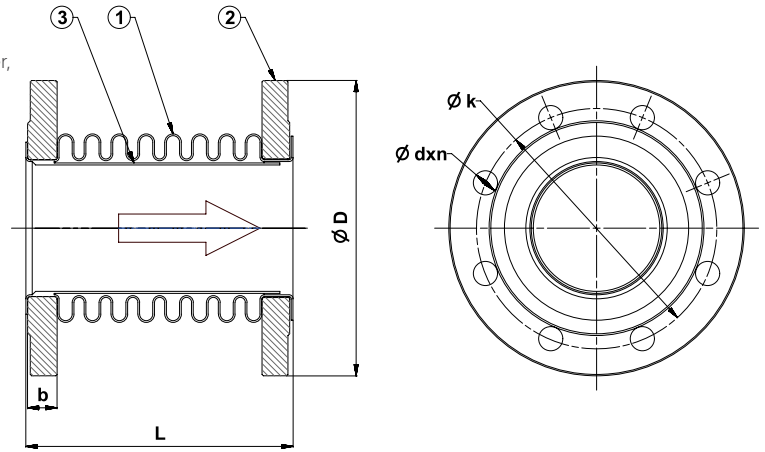

Malzeme Özellikleri Material Specifications

No	Parça Adı / Part Name	Malzeme / Material
1	Körük / Bellow	X5CrNi18 10 - AISI304 - Paslanmaz Çelik / Stainless Steel
2	Flanş / Flange	St37 - Çelik / Steel
3	Layner / Liner	X5CrNi18 10 - AISI304 - Paslanmaz Çelik / Stainless Steel



Ölçüler Dimensions

Anma Basıncı Nominal Pressure	16 Bar												
	DN	25	32	40	50	65	80	100	125	150	200	250	300
T-1820	L 30mm (-20 ... +10mm)	110	110	120	120	120	120	120	125	130	150	165	165
T-1840	L 60mm (-40 ... +20mm)	-	-	-	180	180	180	185	190	200	230	245	245
T-1820	"Eksenel Hareket Axial Movement"	30mm (-20 ... +10mm)											
T-1840		60mm (-40 ... +20mm)											
Boyutlar Dimensions (mm)	ØD	115	140	150	165	185	200	220	250	285	340	405	460
	k	85	100	110	125	145	160	180	210	240	295	355	410
	b	16	18	18	20	20	20	22	22	24	26	29	32
	dxn	14x4	18x4	18x4	18x4	18x4	18x8	18x8	18x8	22x8	22x12	26x12	26x12

Movement 30mm
(- 20 ... +10 mm) DN 25 - 250

Movement 60mm
(- 40 ... +20 mm) DN 50 - 250

T-1950

T-1960

Genel Özellikler / General Specifications

Çalışma Sıcaklık Aralığı / Working Temperature : -80 ... +420°C (16 Bar)

Standartlar / Standards

Sertifikalar / Certificates :

Tasarım / Design : TS 10880

Bağlantı Boyutları / Connection Dimensions : TS EN 1092-1 (PN 16)

Testler / Tests : TS EN 12266-1

Uygulamalar / Applications

Sıcak ve soğuk su sistemleri, basınçlı hava, kızgın su, buhar, kızgın buhar, kızgın yağ sistemleri
Hot and cold water systems, compressed air, superheated water, steam, superheated steam systems, superheated oil systems

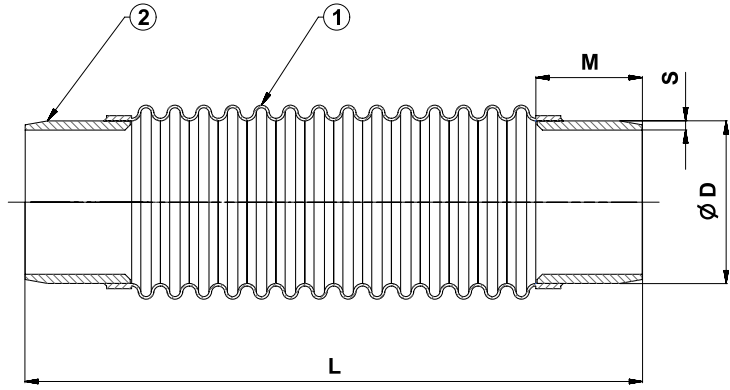

Malzeme Özellikleri Material Specifications

No	Parça Adı / Part Name	Malzeme / Material
1	Körük / Bellow	X5CrNi18 10 - AISI304 - Paslanmaz Çelik / Stainless Steel
2	Kaynak Boynu / Welded Neck	St37 - Çelik / Steel



Ölçüler Dimensions

Anma Basıncı Nominal Pressure	16 Bar												
	DN	25	32	40	50	65	80	100	125	150	200	250	300
T-1950	L 30mm (-20 ... +10mm)	180	180	190	185	185	185	200	200	245	265	310	310
T-1960	L 60mm (-40 ... +20mm)	-	-	-	240	240	245	265	265	315	340	395	395
T-1950	Eksenel Hareket Axial Movement	30mm (-20 ... +10mm)											
T-1960		60mm (-40 ... +20mm)											
Boyutlar Dimensions (mm)	ØD	42,4	42,4	48,3	60,3	76,1	88,9	114,3	139,7	165,1	219,1	273	323,9
	S	3,2	3,2	3,2	3,6	3,6	4	4,5	5	5	6,3	6,3	7,1

Kaynak Ağızı TS 5437'ye Uygundur / Welding Neck is TS 5437 Standard

T-1970 T-1980 T-1985

Genel Özellikler / General Specifications

Çalışma Sıcaklık Aralığı / Working Temperature : -80 ... +420°C (16 Bar)

Genleşme Miktarı

DN 25 - 250

T-1970 Movement 30mm (-20 ... +10 mm)

T-1980 Movement 60mm (-40 ... +20 mm)

T-1985 Movement 90mm (-70 ... +20 mm)

Standartlar / Standards

Sertifikalar / Certificates :

Tasarım / Design : TS 10880

Bağlantı Boyutları / Connection Dimensions : TS EN 1092-1 (PN 16)

Testler / Tests : TS EN 12266-1

Uygulamalar / Applications

Sıcak ve soğuk su sistemleri, basınçlı hava, kızgın su, buhar, kızgın buhar, kızgın yağ sistemleri

Hot and cold water systems, compressed air, superheated water, steam, superheated steam systems, superheated oil systems

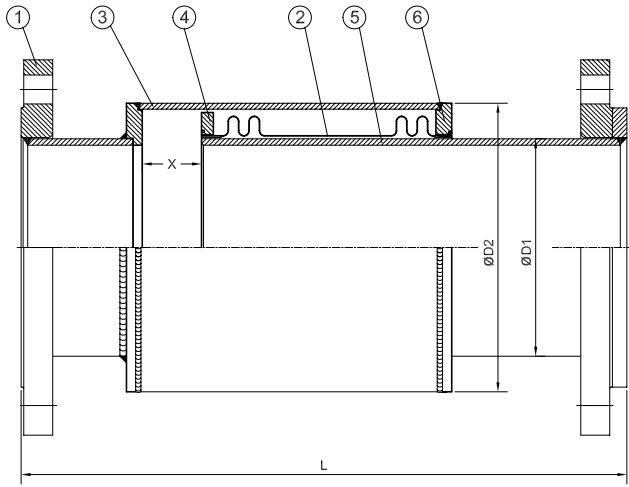

Malzeme Özellikleri Material Specifications

No	Parça Adı / Part Name	Malzeme / Material
1	Flanş / Flange	St37 - Çelik / Steel
2	Körük / Bellow	X5CrNi18 10 - AISI304 - Paslanmaz Çelik / Stainless Steel
3	Dış Boru / Outer Pipe	St33 - Çelik / Steel (DIN 2440B, TS 301/3)
4	İç Flanş / Inner Flange	St37 - Çelik / Steel
5	Kayar Boru / Sliding Pipe	St33 - Çelik / Steel (DIN 2440B, TS 301/3)
6	Dış Flanş / Outer Flange	St37 - Çelik / Steel



Ölçüler Dimensions

Anma Basıncı Nominal Pressure	16 Bar												
Anma Çapı Nominal Diameter	DN	25	32	40	50	65	80	100	125	150	200	250	300
T-1970	L 30mm (-20 ... +10mm)	360	360	380	370	370	370	380	380	400	420	440	460
T-1980	L 60mm (-40 ... +20mm)	490	490	500	480	470	470	480	490	510	530	540	570
T-1985	L 90mm (-70 ... +20mm)	520	520	530	510	500	500	510	520	540	560	570	600
T-1970	"Eksenel Hareket Axial Movement"	30mm (-20 ... +10mm)											
T-1980		60mm (-40 ... +20mm)											
T-1985		90mm (-70 ... +20mm)											
T-1970	x	25											
T-1980		45											
T-1985		65											
Boyutlar Dimensions (mm)	ØD1	42,4	42,4	48,3	60,3	76,1	88,9	114,3	139,7	165,1	219,1	273	323,9
	ØD2	3,2	3,2	3,2	3,6	3,6	4	4,5	5	5	6,3	6,3	7,1

T-1990 T-1995 T-1996

Genel Özellikler / General Specifications

Çalışma Sıcaklık Aralığı / Working Temperature : -80 ... +420°C (16 Bar)

Genleşme Miktarı / Expansion - Compression

DN 25 - 250

T-1990 Movement 30mm (- 20 ... +10 mm)

T-1995 Movement 60mm (- 40 ... +20 mm)

T-1996 Movement 90mm (- 70 ... +20 mm)

Standartlar / Standards

Sertifikalar / Certificates :

Tasarım / Design : TS 10880

Bağlantı Boyutları / Connection Dimensions : TS EN 1092-1 (PN 16)

Testler / Tests : TS EN 12266-1

Uygulamalar / Applications

Sıcak ve soğuk su sistemleri, basınçlı hava, kızgın su, buhar, kızgın buhar, kızgın yağ sistemleri

Hot and cold water systems, compressed air, superheated water, steam, superheated steam systems, superheated oil systems



Malzeme Özellikleri Material Specifications

No	Parça Adı / Part Name	Malzeme / Material
1	Kaynak Boynu / Welded Neck	St37 - Çelik / Steel
2	Körüklü / Bellow	X5CrNi18 10 - AISI304 - Paslanmaz Çelik / Stainless Steel
3	Diş Boru / Outer Pipe	St33 - Çelik / Steel (DIN 2440B, TS 301/3)
4	İç Flanş / Inner Flange	St37 - Çelik / Steel
5	Kayar Boru / Sliding Pipe	St33 - Çelik / Steel (DIN 2440B, TS 301/3)
6	Diş Flanş / Outer Flange	St37 - Çelik / Steel



Ölçüler Dimensions

Anma Basıncı Nominal Pressure	16 Bar												
Anma Çapı Nominal Diameter	DN	25	32	40	50	65	80	100	125	150	200	250	300
T-1990	L 30mm (-20 ... +10mm)	340	340	360	350	350	350	360	360	380	400	420	440
T-1995	L 60mm (-40 ... +20mm)	470	470	480	460	450	450	460	470	490	510	520	550
T-1996	L 90mm (-70 ... +20mm)	500	500	510	490	480	480	490	500	520	540	550	580
T-1990	"Eksenel Hareket Axial Movement"	30mm (-20 ... +10mm)											
T-1995		60mm (-40 ... +20mm)											
T-1996		90mm (-70 ... +20mm)											
T-1990	X	25											
T-1995		45											
T-1996		65											
Boyutlar Dimensions (mm)	ØD1	42,4	42,4	48,3	60,3	76,1	88,9	114,3	139,7	165,1	219,1	273	323,9
	ØD2	3,2	3,2	3,2	3,6	3,6	4	4,5	5	5	6,3	6,3	7,1

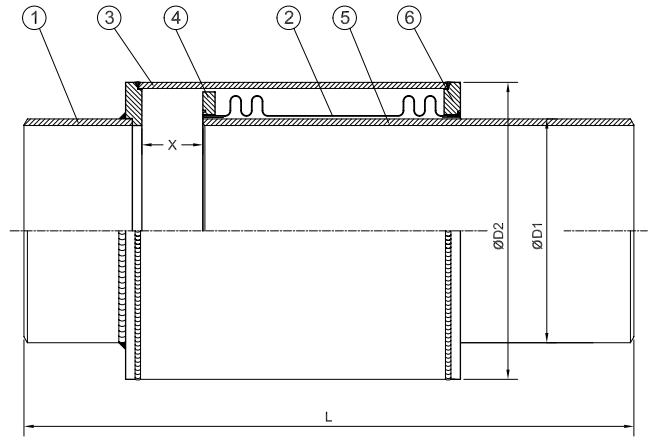

Limit Rotlu Metal Kompansatör PN16 (Flanged) Metal Bellows Expansion Joints, With Limiting Rod PN16 (Flanged)



T-1825 T-1845

Genel Özellikler / General Specifications

Çalışma Sıcaklık Aralığı / Working Temperature : -80 ... +420 °C (16 Bar)

Genleşme Miktarı

DN 25 - 250

T-1825 Movement 30mm (- 20 ... +10 mm)

T-1845 Movement 60mm (- 40 ... +20 mm)

Standartlar / Standards

Sertifikalar / Certificates :

Tasarım / Design : TS 10880

Bağlantı Boyutları / Connection Dimensions : TS EN 1092-1 (PN 16)

Testler / Tests : TS EN 12266-1



Uygulamalar / Applications

Sıcak ve soğuk su sistemleri, basınçlı hava, kızgın su, buhar, kızgın buhar, kızgın yağ sistemleri
Hot and cold water systems, compressed air, superheated water, steam, superheated steam systems, superheated oil systems

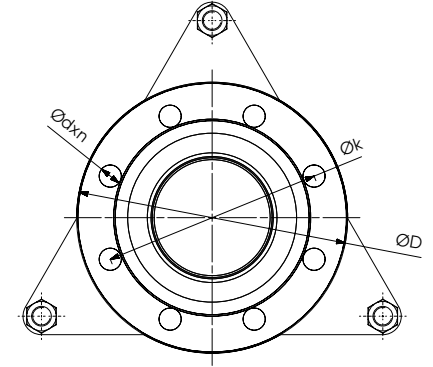
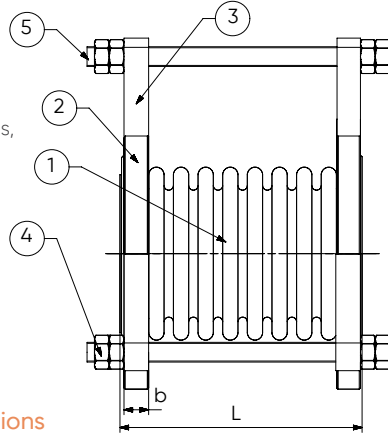

Malzeme Özellikleri Material Specifications

No	Parça Adı / Part Name	Malzeme / Material
1	Körük / Bellow	X5CrNi18 10 Paslanmaz Çelik / Stainless Steel 1.4301
2	Flanş / Flange	X5CrNi18 10 Paslanmaz Çelik / Stainless Steel 1.4301
3	Kulak / Additional Part	X5CrNi18 10 Paslanmaz Çelik / Stainless Steel 1.4301
4	Somun / Intermediate pipe	St37-2 - Çelik / Steel
5	Limit Rot / Limit rod	St37-2 - Çelik / Steel



Ölçüler Dimensions

Anma Basıncı Nominal Pressure	16 Bar													
	DN	25	32	40	50	65	80	100	125	150	200	250	300	
Boyutlar Dimensions (mm)	ØD	115	140	150	165	185	200	220	250	285	340	405	460	
	k	85	100	110	125	145	160	180	210	240	295	355	410	
	b	16	18	18	20	20	20	22	22	24	26	29	32	
	dxn	14x4	18x4	18x4	18x4	18x4	18x8	18x8	18x8	18x8	22x8	22x12	26x12	26x12
	L (30mm)	110	110	120	120	120	120	120	125	130	150	165	165	
	L (60 mm)	-	-	-	180	180	180	185	190	200	230	245	245	

T-2610 T-2620
T-2650



Genel Özellikler / General Specifications

Çalışma Sıcaklık Aralığı / Working Temperature : -80 ... +420°C (16 Bar)

Genleşme Miktarı / Expansion - Compression

DN 25 - 250

(T-2610) Movement Eksenel (Axial) X=100mm, Yanal (Lateral) Y= ±50mm (100) Açısal (Angular) Z=±50mm(100)

(T-2620) Movement Eksenel (Axial) X=100mm, Yanal (Lateral) Y= ±100mm (200) Açısal (Angular) Z=±100mm(200)

(T-2650) Movement Eksenel (Axial) X=100mm, Yanal (Lateral) Y= ±200mm (400) Açısal (Angular) Z=±200mm(400)

Standartlar / Standards

Sertifikalar / Certificates :

Tasarım / Design : TS 10880

Bağlantı Boyutları / Connection Dimensions : TS EN 1092-1 (PN 16)

Testler / Tests : TS EN 12266-1

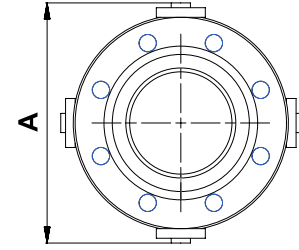

Uygulamalar / Applications

Sıcak ve soğuk su sistemleri, basınçlı hava, kızgın su, buhar, kızgın buhar, kızgın yağ sistemleri, bütün boru hatlarında

Hot and cold water systems, compressed air, superheated water, steam, superheated steam systems, superheated oil systems, all pipe lines



Malzeme Özellikleri Material Specifications

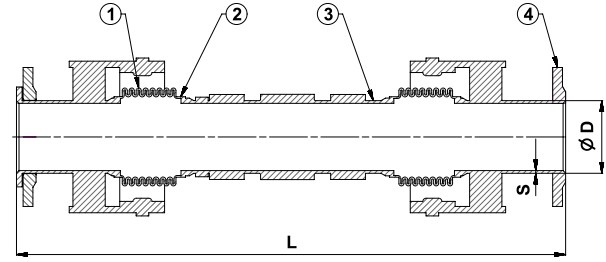

No	Parça Adı / Part Name	Malzeme / Material
1	Körük / Bellow	X5CrNi18 10 - AISI304 - Paslanmaz Çelik / Stainless Steel
2	Bant / Band	X5CrNi18 10 - AISI304 - Paslanmaz Çelik / Stainless Steel
3	Ara Boru / Intermediate Pipe	St37 - Çelik / Steel
4	Flanş / Flange	St37 - Çelik / Steel



Ölçüler Dimensions

Anma Basıncı Nominal Pressure	16 Bar															
	X = Eksenel Hareket / Axial Movement	Y = Yanal Hareket / Lateral Movement	Z = Açısal Hareket / Angular Movement	DN	25	32	40	50	65	80	100	125	150	200	250	300
T-2610	100	±50mm (100)	±50mm (100)	L	720	720	720	800	800	830	850	980	980	1140	1140	1200
T-2620		±100mm (200)	±100mm (200)	L	920	920	920	1000	1000	1030	1050	1180	1180	1340	1340	1400
T-2650		±200mm (400)	±200mm (400)	L	1320	1320	1320	1420	1500	1500	1550	1780	1780	2050	2100	2150
Boyutlar Dimensions (mm)	ØD	42,4	42,4	48,3	60,3	76,1	88,9	114,3	139,7	168,3	219,1	273,1	323,9			
	A	115	140	150	165	185	200	220	250	285	340	405	406			
	S	3,2	3,2	3,2	3,6	3,6	4	4,5	5	5	6,3	6,3	7,1			
	dxn	14x4	18x4	18x4	18x4	18x4	18x8	18x8	18x8	18x8	22x8	22x12	26x12	26x12		

T-2710 T-2720 T-2750



Genel Özellikler / General Specifications

Çalışma Sıcaklık Aralığı / Working Temperature : -80 ... +420°C (16 Bar)

Genleşme Miktarı / Expansion - Compression

DN 25 - 250

(T-2710) Movement Eksenel (Axial) X=100mm, Yanal (Lateral) Y= ±50mm (100) Açısal (Angular) Z=±50mm (100)

(T-2720) Movement Eksenel (Axial) X=100mm, Yanal (Lateral) Y= ±100mm (200) Açısal (Angular) Z=±100mm(200)

(T-2750) Movement Eksenel (Axial) X=100mm, Yanal (Lateral) Y= ±200mm (400) Açısal (Angular) Z=±200mm(400)

Standartlar / Standards

Sertifikalar / Certificates :

Tasarım / Design : TS 10880

Bağlantı Boyutları / Connection Dimensions : TS EN 1092-1 (PN 16)

Testler / Tests : TS EN 12266-1

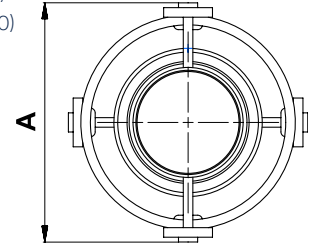

Uygulamalar / Applications

Sıcak ve soğuk su sistemleri, basınçlı hava, kızgın su, buhar, kızgın buhar, kızgın yağ sistemleri, bütün boru hatlarında
Hot and cold water systems, compressed air, superheated water, steam, superheated steam systems, superheated oil systems, all pipe lines

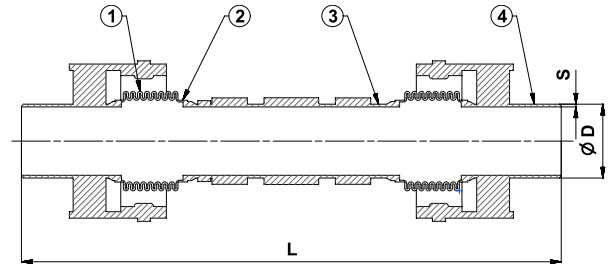

Malzeme Özellikleri Material Specifications

No	Parça Adı / Part Name	Malzeme / Material
1	Körük / Bellow	X5CrNi18 10 - AISI304 - Paslanmaz Çelik / Stainless Steel
2	Bant / Band	X5CrNi18 10 - AISI304 - Paslanmaz Çelik / Stainless Steel
3	Ara Boru / Intermediate Pipe	St37 - Çelik / Steel
4	Kaynak Boynu / Welded Neck	St37 - Çelik / Steel



Ölçüler Dimensions

Anma Basıncı Nominal Pressure	16 Bar																		
	Anma Çapı Nominal Diameter	X = Eksenel Hareket / Axial Movement	Y = Yanal Hareket / Lateral Movement	Z = Açısal Hareket / Angular Movement	DN	25	32	40	50	65	80	100	125	150	200	250	300		
T-2710					100	±50mm (100)	±50mm (100)	L	710	710	710	790	785	815	835	965	965	1125	1125
	T-2720	±100mm (200)	±100mm (200)	910					910	910	990	985	1015	1035	1165	1165	1325	1325	1385
	T-2750	±200mm (400)	±200mm (400)	1310					1310	1310	1410	1485	1485	1535	1765	1765	2035	2085	2135
Boyutlar Dimensions (mm)					ØD	42,4	42,4	48,3	60,3	76,1	88,9	114,3	139,7	168,3	219,1	273	323,9		
					A	147	147	160	180	200	218	266	292	347	412	464	515		
					S	3,2	3,2	3,2	3,6	3,6	4	4,5	5	5	6,3	6,3	7,1		

T-2420 T-2440
T-2460 T-2480

Genel Özellikler / General Specifications

Çalışma Sıcaklık Aralığı / Working Temperature :
-80 ... +420°C (16 Bar) Genleşme Miktarı / Expansion - Compression

DN 25 - 50

T-2420 Movement Eksenel (Axial) X=30mm, Yanal (Lateral) Y= ±50mm (100)
T-2440 Movement Eksenel (Axial) X=30mm, Yanal (Lateral) Y= ±100mm (200)

DN 65 - 300

T-2460 Movement Eksenel (Axial) X=60mm, Yanal (Lateral) Y= ±50mm (100)
T-2480 Movement Eksenel (Axial) X=60mm, Yanal (Lateral) Y= ±100mm (200)

Standartlar / Standards

Sertifikalar / Certificates :
Tasarım / Design : TS 10880
Bağlantı Boyutları / Connection Dimensions : TS EN 1092-1 (PN 16)
Testler / Tests : TS EN 12266-1

Uygulamalar / Applications

Sıcak ve soğuk su sistemleri, basınçlı hava, kızgın su, buhar, kızgın buhar, kızgın yağ sistemleri
Hot and cold water systems, compressed air, superheated water, steam, superheated steam systems, superheated oil systems



Malzeme Özellikleri Material Specifications

No	Parça Adı / Part Name	Malzeme / Material
1	Flanş / Flange	St37-2 - Çelik / Steel
2	Körük / Bellow	X5CrNi18 10 Paslanmaz Çelik / Stainless Steel 1.4301
3	Bant / Band	X5CrNi18 10 Paslanmaz Çelik / Stainless Steel 1.4301
4	Ara Boru / Intermediate Pipe	St37-2 - Çelik / Steel
5	Limit Rot / Limit Rod	St37-2 - Çelik / Steel



Ölçüler Dimensions

Anma Basıncı Nominal Pressure	16 Bar															
Anma Çapı Nominal Diameter	X = Eksenel Hareket / Axial Movement	Y = Yanal Hareket / Lateral Movement	Z = Açısal Hareket / Angular Movement	DN	25	32	40	50	65	80	100	125	150	200	250	300
T-2420	30	±50mm (100)			L	350	350	350	450	-	-	-	-	-	-	-
T-2440		±100mm (200)				550	550	550	650	-	-	-	-	-	-	-
T-2460	60	±50mm (100)			-	-	-	-	450	500	500	650	650	700	800	950
T-2480		±100mm (200)			-	-	-	-	650	700	700	850	850	900	1000	1150
Boyutlar Dimensions (mm)	ØD															
	k															
	b															
	dxn															

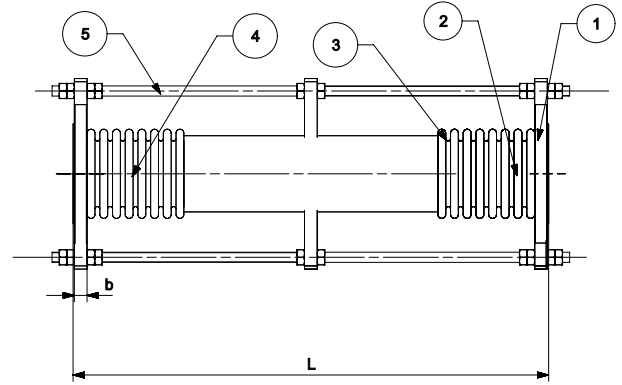
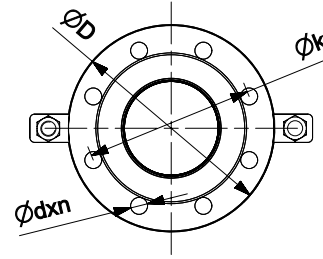

T-2520 T-2540
T-2560 T-2580



Genel Özellikler / General Specifications

Çalışma Sıcaklık Aralığı / Working Temperature :
-80 ... +420°C (16 Bar) Genleşme Miktarı / Expansion - Compression

DN 25 - 50

T-2520 Movement Eksenel (Axial) X=30mm, Yanal (Lateral) Y= ±50mm (100)
T-2540 Movement Eksenel (Axial) X=30mm, Yanal (Lateral) Y= ±100mm (200)

DN 65 - 300

T-2560 Movement Eksenel (Axial) X=60mm, Yanal (Lateral) Y= ±50mm (100)
T-2580 Movement Eksenel (Axial) X=60mm, Yanal (Lateral) Y= ±100mm (200)

Standartlar / Standards

Sertifikalar / Certificates :
Tasarım / Design : TS 10880
Bağlantı Boyutları / Connection Dimensions : TS EN 1092-1 (PN 16)
Testler / Tests : TS EN 12266-1

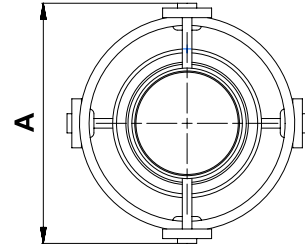

Uygulamalar / Applications

Sıcak ve soğuk su sistemleri, basınçlı hava, kızgın su, buhar, kızgın buhar, kızgın yağ sistemleri
Hot and cold water systems, compressed air, superheated water, steam, superheated steam systems, superheated oil systems

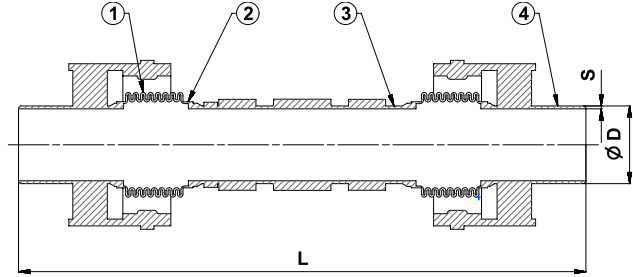

Malzeme Özellikleri Material Specifications

No	Parça Adı / Part Name	Malzeme / Material
1	Kaynak Boynu / Welded Neck	St37 - Çelik / Steel
2	Körük / Bellow	X5CrNi18 10 - AISI304 - Paslanmaz Çelik / Stainless Steel
3	Bant / Band	X5CrNi18 10 - AISI304 - Paslanmaz Çelik / Stainless Steel
4	Ara Boru / Intermediate Pipe	St37 - Çelik / Steel
5	Limit Rot / Limit Rod	St37 - Çelik / Steel



Ölçüler Dimensions

Anma Basıncı Nominal Pressure	16 Bar															
	X = Eksenel Hareket Axial Movement	Y = Yanal Hareket Lateral Movement	Z = Açısal Hareket Angular Movement	DN	25	32	40	50	65	80	100	125	150	200	250	300
T-2520	30	±50mm (100)	L	640	640	640	710	-	-	-	-	-	-	-	-	-
T-2540				840	840	840	910	-	-	-	-	-	-	-	-	-
T-2560	60	±50mm (100)	L	-	-	-	-	710	760	760	900	900	950	1050	1200	
T-2580				-	-	-	-	910	960	960	1100	1100	1150	1250	1400	
Boyutlar Dimensions [mm]	ØD			42,4	42,4	48,3	60,3	76,1	88,9	114,3	139,7	168,3	219,1	273	323,9	
	s			3,2	3,2	3,2	3,6	3,6	4	4,5	5	5	6,3	6,3	7,1	
	A			147	147	147	161	189	211	242	282	327	419	491	542	

Pirinç Dövme / Forced Brass

T-2110

Genel Özellikler / General Specifications

Çalışma Sıcaklık Aralığı / Working Temperature : -10 ... +120 °C (25 Bar)

Standartlar / Standards

Sertifikalar / Certificates :

Tasarım / Design : TS EN 13547

Diş Standardı / Thread Standard : EN ISO 228-1

Testler / Tests : TS EN 12266-1

Uygulamalar / Applications

Sıcak ve soğuk su sistemleri, basınçlı hava, asit ve alkali özelliği bulunmayan sıvı akışkanlar
Hot and cold water systems, compressed air, non-acidic and non-flammable liquid fluids

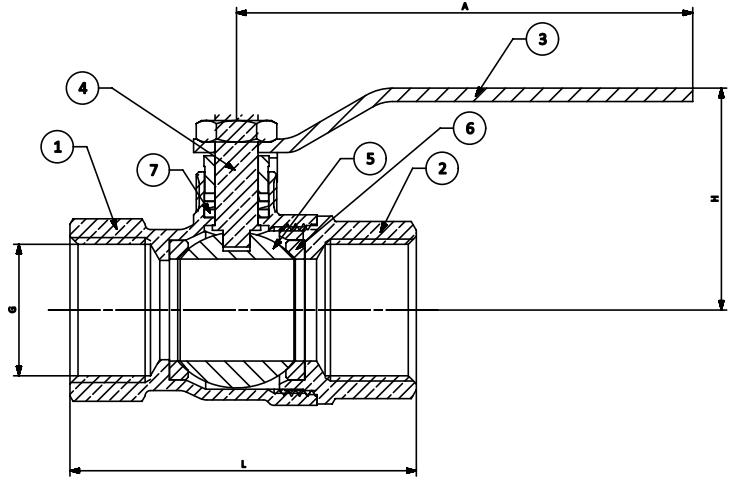

Malzeme Özellikleri Material Specifications

No Parça Adı / Part Name

- Gövde / Body
- Kapak / Bonnet
- Kol / Lever
- Mil / Stem
- Küre / Ball
- Ringler / Seals
- Salmastra

Malzeme / Material

- CuZn40Pb2 - CW617N - Pirinç Dövme / Forced Brass
CuZn40Pb2 - CW617N - Pirinç Dövme / Forced Brass
St37 - Çelik + Galvaniz + Vinil Kaplama / Steel + Galvanize Plated + Vinyl Coated
CuZn40Pb2 - CW617N - Pirinç / Brass
CuZn40Pb2 - CW617N - Pirinç + Krom Kaplama / Brass + Chrome Plated
PTFE - Teflon
PTFE - Teflon



Ölçüler Dimensions

Anma Basıncı Nominal Pressure	25 Bar							16 Bar		
Anma Çapı Nominal Diameter	DN	15	20	25	32	40	50	65	80	100
Vana Boyutları Valve Dimensions	G	1/2"	3/4"	1"	1 1/4"	1 1/2"	2"	2 1/2"	3"	4"
	L	46	55	65	80	90	104	150	180	
	H	40	45	60	65	80	85	110	122	132
	A	83		117		163		220		
Ağırlık Weight	Kg	0,15	0,23	0,45	0,65	0,96	1,43	3,63	5,6	9,1

Pirinç Dövme / Forced Brass

T-2120



Genel Özellikler / General Specifications

Çalışma Sıcaklık Aralığı / Working Temperature : -10 ... +120°C (25 Bar)

Standartlar / Standards

Sertifikalar / Certificates :

Tasarım / Design : TS EN 13547

Diş Standardı / Thread Standard : EN ISO 228-1

Testler / Tests : TS EN 12266-1

Uygulamalar / Applications

Sıcak ve soğuk su sistemleri, basınçlı hava, asit ve alkali özelliği bulunmayan sıvı akışkanlar
Hot and cold water systems, compressed air, non-acidic and non-flammable liquid fluids

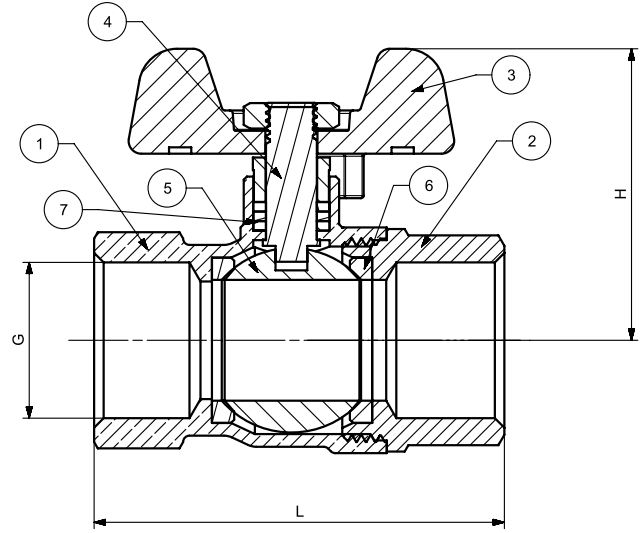

Malzeme Özellikleri Material Specifications

No Parça Adı / Part Name

- 1 Gövde / Body
- 2 Kapak / Bonnet
- 3 Kol / Lever
- 4 Mil / Stem
- 5 Küre / Ball
- 6 Ringler / Seals
- 7 Salmastra

Malzeme / Material

- CuZn40Pb2 - CW617N - Pirinç Dövme / Forced Brass
CuZn40Pb2 - CW617N - Pirinç Dövme / Forced Brass
Alüminyum Enjeksiyon + Elektrostatik Boya / Aluminum Injection + Electrostatic Painting
CuZn40Pb2 - CW617N - Pirinç / Brass
CuZn40Pb2 - CW617N - Pirinç + Krom Kaplama / Brass + Chrome Plated
PTFE - Teflon
PTFE - Teflon



Ölçüler Dimensions

Anma Basıncı Nominal Pressure	25 Bar			
Anma Çapı Nominal Diameter	DN	15	20	25
Vana Boyutları Valve Dimensions	G	1 / 2"	3 / 4"	1"
	L	46	55	60
	H	40	45	50
Ağırlık Weight	Kg	0,15	0,23	0,45

Pirinç Dövme / Forced Brass

T-2130

Genel Özellikler / General Specifications

Çalışma Sıcaklık Aralığı / Working Temperature : -10... +120 °C (25 Bar)

Standartlar / Standards

Sertifikalar / Certificates :

Tasarım / Design : TS EN 13547

Diş Standardı / Thread Standard : EN ISO 228-1

Testler / Tests : TS EN 12266-1

Uygulamalar / Applications

Sıcak ve soğuk su sistemleri, basınçlı hava, asit ve alkali özelliği bulunmayan sıvı akışkanlar
Hot and cold water systems, compressed air, non-acidic and non-flammable liquid fluids

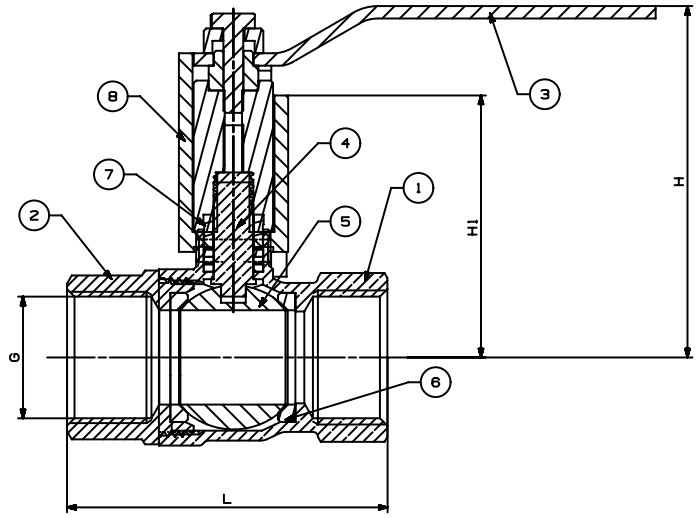

Malzeme Özellikleri Material Specifications

No Parça Adı / Part Name

- Gövde / Body
- Kapak / Bonnet
- Kol / Lever
- Mil / Stem
- Küre / Ball
- Ringler / Seals
- Salmastra
- Boyun / Neck

Malzeme / Material

- CuZn40Pb2 - CW617N - Pirinç Dövme / Forced Brass
CuZn40Pb2 - CW617N - Pirinç Dövme / Forced Brass
St.37 - Çelik + Galvaniz + Vinil Kaplama / Steel + Galvanize Plated + Vinyl Coated
CuZn40Pb2 - CW617N - Pirinç / Brass
CuZn40Pb2 - CW617N - Pirinç + Krom Kaplama / Brass + Chrome Plated
PTFE - Teflon
PTFE - Teflon
Zamak Enjeksiyon / Zamak Injection



Ölçüler Dimensions

Anma Basıncı Nominal Pressure	25 Bar						
Anma Çapı Nominal Diameter	DN	15	20	25	32	40	50
Vana Boyutları Valve Dimensions	G	1 / 2"	3 / 4"	1"	1 1 / 4"	1 1 / 2"	2"
	L	46	55	65	80	90	104
	H	65	68	81	86	113	120
	H1	45	48	55	60	81	90
	A	86		115		155	
Ağırlık Weight	Kg.	0,27	0,35	0,6	0,76	1,13	1,6

Pirinç Dövme / Forced Brass

T-2160

Genel Özellikler / General Specifications

Çalışma Sıcaklık Aralığı / Working Temperature : -10 ... +110 °C (16 Bar)
"Pik Kullanım Sıcaklığıdır"

Standartlar / Standards

Sertifikalar / Certificates :

Tasarım / Design : TS EN 13547

Dış Standardı / Thread Standard : EN ISO 228-1

Testler / Tests : TS EN 12266-1

Uygulamalar / Applications

Sıcak ve soğuk su sistemleri, basınçlı hava
Hot and cold water systems, compressed air

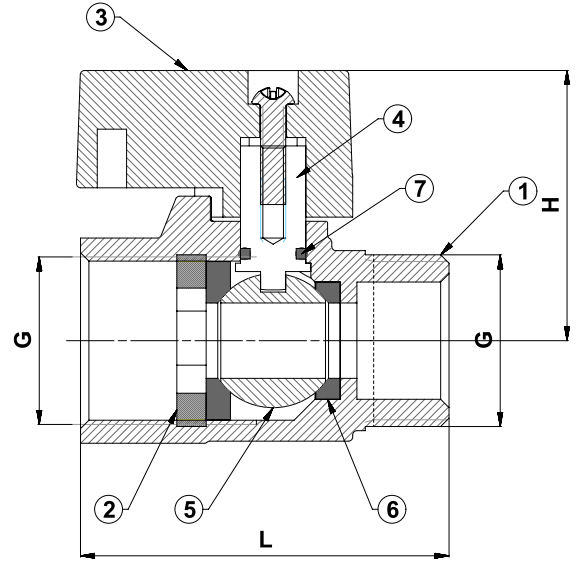

Malzeme Özellikleri Material Specifications

No	Parça Adı / Part Name	Malzeme / Material
1	Gövde / Body	CuZn40Pb2 - CW617N - Pirinç Dövme / Forced Brass
2	Kapak / Bonnet	CuZn40Pb2 - CW617N - Pirinç / Brass
3	Kol / Lever	Alüminyum Enjeksiyon + Elektrostatik Boya / Aluminum Injection + Electrostatic Painting
4	Mil / Stem	CuZn40Pb2 - CW617N - Pirinç / Brass
5	Küre / Ball	CuZn40Pb2 - CW617N - Pirinç + Krom Kaplama / Brass + Chrome Plated
6	Ringler / Seals	PTFE - Teflon
7	O-Ring	EPDM



Ölçüler Dimensions

Anma Basıncı Nominal Pressure	16 Bar	
Anma Çapı Nominal Diameter	DN	15
Vana Boyutları Valve Dimensions	G	1/2"
	L	46
	H	32
Ağırlık Weight	Kg	0.140

Pirinç Dövme / Forced Brass

T-2210



Genel Özellikler / General Specifications

Çalışma Sıcaklık Aralığı / Working Temperature : -10 ... +110°C (16 Bar)

Standartlar / Standards

Sertifikalar / Certificates :

Tasarım / Design : TS 10873

Diş Standardı / Thread Standard : EN ISO 228-1

Testler / Tests : TS EN 12266-1

Uygulamalar / Applications

Sıcak ve soğuk su sistemleri, basınçlı hava, asit ve alkali özelliği bulunmayan sıvı akışkanlar
Hot and cold water systems, compressed air, non-acidic and non-flammable liquid fluids

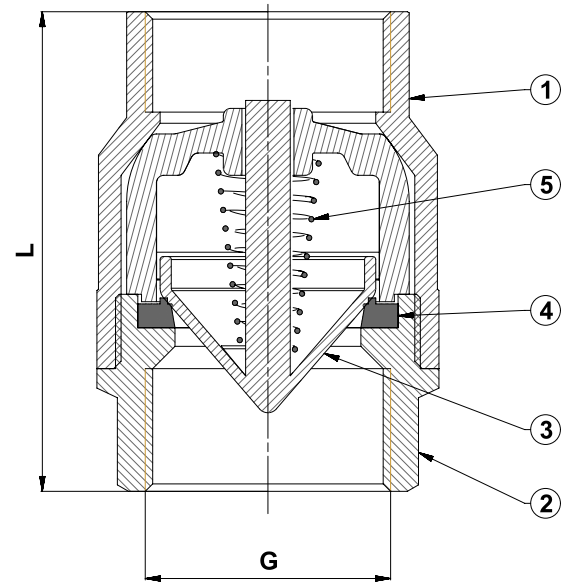

Malzeme Özellikleri Material Specifications

No	Parça Adı / Part Name	Malzeme / Material
1	Gövde / Body	CuZn40Pb2 - CW617N - Pirinç Dövme / Forced Brass
2	Kapak / Bonnet	CuZn40Pb2 - CW617N - Pirinç Dövme / Forced Brass
3	Klape / Clapper	Polimer Plastik / Polymer Plastic
4	Conta / Gasket	NBR
5	Yay / Spring	X12CrNi18 8 - AISI302 - Paslanmaz Çelik / Stainless Steel



Ölçüler Dimensions

Anma Basıncı Nominal Pressure	16 Bar									
Anma Çapı Nominal Diameter	DN	15	20	25	32	40	50	65	80	100
Vana Boyutları Valve Dimensions	G	1 / 2"	3 / 4"	1"	1 1 / 4"	1 1 / 2"	2"	2 1 / 2"	3"	4"
	L	49	53	58	67	71	79	93	102	120
Ağırlık Weight	Kg	0.1	0.14	0.24	0.33	0.5	0.7	1,55	1,9	3

Pirinç Dövme / Forced Brass

T-2220

Genel Özellikler / General Specifications

Çalışma Sıcaklık Aralığı / Working Temperature : -10 ... +110 °C (16 Bar)

"Pik Kullanım Sıcaklığıdır"

Standartlar / Standards

Sertifikalar / Certificates :

Tasarım / Design : TS 11494

Diş Standardı / Thread Standard : EN ISO 228-1

Testler / Tests : TS EN 12266-1

Uygulamalar / Applications

Sıcak ve soğuk su sistemleri, basınçlı hava,
doymuş buhar, asit ve alkali özelliği bulunmayan sıvı akışkanlar
Hot and cold water systems, compressed air,
saturated steam, non-acidic and non-flammable liquid fluids

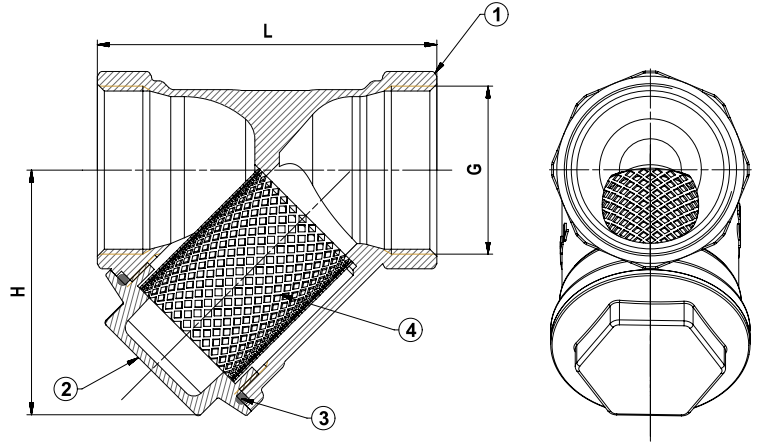

Malzeme Özellikleri Material Specifications

No	Parça Adı / Part Name	Malzeme / Material
1	Gövde / Body	CuZn40Pb2 - CW617N - Pirinç Dövme / Forced Brass
2	Kapak / Bonnet	CuZn40Pb2 - CW617N - Pirinç Dövme / Forced Brass
3	O-Ring	EPDM
4	Filtre / Filter	X5CrNi18 10 - AISI304 - Paslanmaz Çelik / Stainless Steel



Ölçüler Dimensions

Anma Basıncı Nominal Pressure	16 Bar								
Anma Çapı Nominal Diameter	DN	15	20	25	32	40	50	65	80
Vana Boyutları Valve Dimensions	G	1 / 2"	3 / 4"	1"	1 1 / 4"	1 1 / 2"	2"	2 1 / 2"	3"
	L	58	68	75	90	108	130	150	180
	H	36	50	57	64	75	87	111	127
Ağırlık Weight	Kg	0,106	0,149	0,233	0,420	0,483	0,793	1,306	1,838
Filtre Filter		30 Mesh (600 Mikron-Micron)							

Pirinç Dövme / Forced Brass

T-2260

Genel Özellikler / General Specifications

Çalışma Sıcaklık Aralığı / Working Temperature : -10... +90 °C (10 Bar)

Standartlar / Standards

Sertifikalar / Certificates :

Tasarım / Design : TS 7817

Diş Standardı / Thread Standard : EN ISO 228-1

Testler / Tests : TS EN 12266-1

Uygulamalar / Applications

Sıcak ve soğuk su sistemleri
Hot and cold water systems

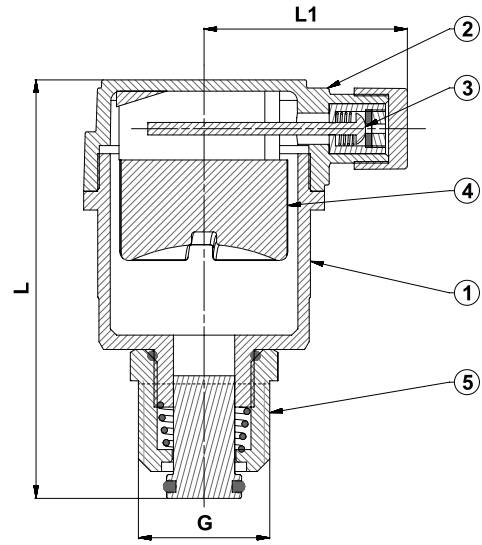

Malzeme Özellikleri Material Specifications

No	Parça Adı / Part Name	Malzeme / Material
1	Gövde / Body	CuZn40Pb2 - CW617N - Pirinç Dövme / Forced Brass
2	Kapak / Bonnet	CuZn40Pb2 - CW617N - Pirinç Dövme / Forced Brass
3	Emniyet Subabı / Safety Valve	Ebonit / Ebonite
4	Şamandıra / Float	Ebonit / Ebonite
5	Çek Vana / Check Valve	CuZn40Pb2 - CW617N - Pirinç Dövme / Forced Brass



Ölçüler Dimensions

Anma Basıncı Nominal Pressure	10 Bar	
Vana Boyutları Valve Dimensions	G	1 / 2"
	L	71
	L1	29
Ağırlık Weight	Kg	0.13

DIN 2401 Malzeme & Sıcaklık Bağlantı Normu

PN	Vanalar				Sıcaklığa (°C) göre max. Çalışma basıncı (bar)																
	Demir döküm	Sfero döküm	Çelik Döküm	Çelik	20 (120)	200	250	300	350	400	425	450	475	500	510	520	530	540	550		
1	GG 25	GGG 40		St-37/2	1																
					1	1	1	1													
2,5	GG 25	GGG 40		St-37/2	2,5																
					2,5	2	1,8	1,5													
6	GG 25	GGG 40	GS 45	St-37/2	6																
					6	5	4,5	3,6													
10	GG 25	GGG 40	GS 45	St-37/2	10																
					10	8	7	6													
16	GG 25	GGG 40	GS 45	St-37/2	16																
					16	13	11	11													
			GS-C 25	C 22 N	16	14	13	10													
25		GGG 40	GS-45.5	C 22 N	25																
			GS-C 25		25	20	18	16													
			GS-22 Mo4		25	22	20	17	16	14											
			GS-17CrMO 55	15 Mo 3			25	22	20	19	18	17									
			13 CrMO 44				25	24	23	22	21	20	18	15	12	0					
40			GS-45.5	C 22 N	40	32	28	24													
			GS-C25		40	35	32	28	24	21											
			GS-22 Mo4		15 Mo 3			40	35	31	30	29	28								
			GS-17CrMO 55	13 CrMO 44					40	38	36	35	34	33	29	24	19	14			
63			GS-C 25	C 22 N	63	36	29	24													
					63	50	45	40													
					63	50	45	40	36	32											
			GS-22 Mo4	15 Mo 3			64	56	50	47	46	45									
			13 CrMO 44				54	61	58	57	56	53	47	40	32	25					
100			GS-C 25	C 22 N	100	80	70	60													
					100																
					100	80	70	60	56	50											
			GS-22 Mo4	15 Mo 3			100	87	78	74	72	70									
			13 CrMO 44				100	95	91	89	87	82	74	62	49	38					
160			GS-C 25	C 22 N	160	130	112	96													
					160																
					160	130	112	96	90	80											
			GS-22 Mo4	15 Mo 3			160	139	125	118	115	112									
			13 CrMO 44				160	153	146	142	139	132	118	100	79	62	49	35			
			10 CrMO 9 10													70	61	52			
250			GS-C 25	C 22 N	250	200	175	150													
					250																
					250	200	175	150	140	125											
			GS-22 Mo4	15 Mo 3			250	217	196	185	179	174									
			13 CrMO 44				250	238	227	223	217	206	184	154	124	97	73	54			
			10 CrMO 9 10												124	108	95	81			
320			GS-22 Mo4	C 22 N	320	250	225	192													
					320																
					320	250	225	192	180	160											
			GS-22 Mo4	15 Mo 3			320	278	250	236	230	222									
			13 CrMO 44				320	304	292	285	278	264	237	200	158	124	93	60			
			10 CrMO 9 10												58	139	121	104			
400			GS-C 25	C 22 N	400	320	280	240													
					400																
					400	320	280	240	225	200											
			GS22 M04	15 Mo 3			400	348	312	296	286	278									
			13 CrMO 44				400	380	364	356	348	330	295	250	198	155	116	87			
			10 CrMO 9 10												198	174	151	130			



DUYAR

Since 1965

Fabrika & Merkez / Main Factory & Headquarters
Osmangazi Mh. 2653 Sk. No:7 Esenyurt / İstanbul - Turkey
Faks: +90 212 355 07 47

Dökümhane / Foundry
Adnan Kahveci Mah. Tersane Cad. No:1
Beylikdüzü / İstanbul - Turkey
Telefon: +90 212 855 5222

Ofis / Office
Oruç Reis Mh. Tekstilkent Cad. No: 12B
Koza Plaza A Blok Kat:26 No: 262 Esenler / İstanbul - Turkey
Faks: +90 212 355 07 47

+90 444 82 62

+90 (212) 668 18 08

f t i n e /DuyarVana



duyar.com
info@duyar.com